

Copies of this document may be purchased from:

INCITS xxx-200x

Global Engineering, 15 Inverness Way East, T11/Project 1824-DT/Rev 1.1
Englewood, CO 80112-5704
Phone: (800) 854-7179 or (303) 792-2181 Fax: (303) 792-2192

T11/10-367v0

FIBRE CHANNEL

Simplified Configuration and Management

(FC-SCM)
REV 1.1

INCITS working draft proposed
Technical Report 04 August 2010

Secretariat: Information Technology Industry Council

NOTE:

This is a working draft Technical Report of Accredited Standards Committee INCITS. As such this is not a completed Technical Report. The T11 Technical Committee or anyone else may modify this document as a result of comments received anytime, or during a future public review and its eventual approval as a Technical Report. Use of the information contained herein is at your own risk.

Permission is granted to members of INCITS, its technical committees, and their associated task groups to reproduce this document for the purposes of INCITS standardization activities without further permission, provided this notice is included. All other rights are reserved. Any duplication of this document for commercial or for-profit use is strictly prohibited.

POINTS OF CONTACT:

Steve Wilson (T11 Chair)
Brocade Communications
1745 Technology Drive
San Jose, CA 95131
Voice: 408-333-
Fax: 408-392-6676
swilson@brocade.com

Claudio Desanti (T11 Vice Chair)
Cisco Systems, Inc.
170 W. Tasman Dr.
San Jose, CA 95134
Voice: 408-853-9172
Fax: 408-853-9172
cds@cisco.com

Craig W. Carlson (T11.3 Chair)
QLogic Corporation
6321 Bury Drive
Eden Prairie, MN 55346
Voice: 952-932-4064
Fax: 952-932-4037
craig.carlson@qlogic.com

Claudio Desanti (Facilitator)
Cisco Systems, Inc.
170 W. Tasman Dr.
San Jose, CA 95134
Voice: 408-853-9172
Fax: 408-853-9172
cds@cisco.com

William Martin (Editor)
Emulex
532 Gibson Dr. Suite 100
Roseville, CA 95678
Voice: 916-765-6875
bill.martin@emulex.com

Release Notes:

Rev 0.1 08-284v0 - 25 May 2008

- a) Initial version of technical report.

Rev 0.2 08-284v1 - 08 July 2008

- a) Modification requested by working group to modify the Scope clause to limit the applicability to only apply to end devices that implement the SCSI-FCP FC-4.
- b) Changes from June ad hoc meeting - restore document without OLZ

Rev 0.3 09-023v0 12 December 2008

- a) Incorporated necessary part of 08-537v2 in 4.1
- b) Incorporated 08-249v5

Rev 0.4 09-023v1 2 April 2009

- a) Updated formatting and variable
- a) Changes to be consistent with T11 template
 - A) removed byte ordering clause
 - B) updated editorial conventions clause
- b) Incorporated 09-038v3

Rev 0.5 09-023v2 2 June 2009

- a) Changes from Conference call

Rev 0.6 09-023v3 3 August 2009

- a) Changes from June Ad Hoc
- b) Fixed format for transition statements in Initiator state machine

Rev 0.7 09-023v4 5 August 2009

- a) Added 09-206v5
- b) Additional modifications from working group
- c) Changed all Nx_Ports to N_Ports as this technical report limits use to N_Ports.

Rev 0.8 09-023v5 23 September 2009

- a) Added changes from 09-503v2
- b) Removed 5.4 header as this is covered in 7.3
- c) Removed 5.5 header as this is covered in 8.2.2

- d) Made state transition wording format consistent

Rev 0.9 09-023v6 06 October 2009

- a) Added changes from 09-533v1

Rev 1.0 09-023v7 08 December 2009

- a) Added changes from 09-605v2
- b) Added changes from 09-623v0
- c) Removed prohibited, invocable, and allowed

Rev 1.1 10-367v0 04 August 2010

- a) Incorporated all comment resolutions from 10-017v6
- b) Incorporated 10-124v3
- c) Incorporated 10-304v2

BSR INCITS xxx-200x

American National Standard
for Information Technology

Fibre Channel —
Simplified Configuration and Management (FC-SCM)

Secretariat

Information Technology Industry Council

Approved (not yet approved)

American National Standards Institute, Inc.

Abstract

This Technical Report describes a simplified Fibre Channel configuration and management. The Physical Interface requirements are described in Fibre Channel-Physical Interfaces - 2 (FC-PI-2). The Framing and Signaling requirements are described in Fibre Channel-Physical Framing and Signaling - 2 (FC-FS-2). This Technical Report is recommended for new implementations, but does not obsolete the existing Fibre Channel standards.

This technical report is one in a series produced by the American National Standards Committee, INCITS, Information Technology. The secretariat for INCITS is held by the Computer and Business Equipment Manufacturers Association (CBEMA), 1250 Eye Street, NW Suite 200, Washington DC 20005.

As a by-product of the standards development process and the resources of knowledge devoted to it, INCITS from time to time produces Technical Reports. Such Technical Reports are not standards, nor are they intended to be used as such.

INCITS Technical Reports are produced in some cases to disseminate the technical and logical concepts reflected in standards already published or under development. In other cases, they derive from studies in areas where it is found premature to develop a standard due to a still changing technology, or inappropriate to develop a rigorous standard due to the existence of a number of viable options, the choice of which depends on the user's particular requirements. These Technical Reports, thus, provide guidelines, the use of which can result in greater consistency and coherence of information processing systems.

When the draft technical report is completed, the Technical Committee approval process is the same as for a draft standard. Processing by INCITS is also similar to that for a draft standard.

CAUTION: The developers of this technical report have requested that holder's of patents that may be required for the implementation of this technical report disclose such patents to the publisher. However, neither the developers nor the publisher have undertaken a patent search in order to identify which, if any, patents may apply to this technical report.

As of the date of publication of this technical report and following calls for the identification of patents that may be required for the implementation of this technical report, no such claims have been made. No further patent search is conducted by the developer or the publisher in respect to any technical report it processes. No representation is made or implied that licenses are not required to avoid infringement in the use of this technical report.

Published by

**American National Standards Institute
11 West 42nd Street, New York, NY 10036**

Copyright © 200x by American National Standards Institute
All rights reserved.

No part of this publication may be reproduced in any form, in an electronic retrieval system or otherwise, without prior written permission of ITI, 1250 Eye Street NW, Washington, DC 20005.

Printed in the United States of America

Foreword (This Foreword is not part of American National Standard INCITS xxx-200x.)

The Fibre Channel Simplified Configuration and Management (FC-SCM) technical report describes the Fibre Channel requirements for an easy-to-use limited SAN configuration.

This technical report was developed by Task Group T11 of Accredited Standards Committee INCITS during 2007-200x. The technical report approval process started in 200x. This document includes annexes that are informative and are not considered part of the technical report.

Requests for interpretation, suggestions for improvements or addenda, or defect reports are welcome. They should be sent to the INCITS Secretariat, Information Technology Industry Council, 1250 Eye Street, NW, Suite 200, Washington, DC 20005-3922.

This technical report was processed and approved for submittal to ANSI by the International Committee for Information Technology Standards (INCITS). Committee approval of the technical report does not necessarily imply that all committee members voted for approval.

At the time it approved this technical report, INCITS had the following members:

(to be filled in by INCITS)

Technical Committee T11 on ~~FibreChannel~~Fibre Channel Interfaces, which reviewed this ~~standard~~technical report, had the following members:

Steve Wilson, Chair
Claudio DeSanti, Vice-Chair
Bob Nixon, Secretary

(to be filled in prior to submission to INCITS)

Task Group T11.3 on Interconnection Schemes, which developed and reviewed this ~~standard~~technical report, had the following members:

Craig W. Carlson, Chair
William Martin, Vice-Chair
Landon Noll, Secretary

(to be filled in prior to submission to INCITS)

Introduction

FC-SCM is one of the Fibre Channel family of documents. This family includes FC-FS-3, which specifies the Framing and Signalling Interface and FC-PI-5, which specifies the Physical Interface; i.e., cables, connectors, transceivers.

FC-SCM describes a simplified configuration and management for Fibre Channel. The primary upper layer protocol (called FC-4) for which provisions are made in this document is FCP-4 (Fibre Channel Protocol for SCSI).

Acknowledgements

~~The technical editor would like to thank the following individuals for their special contributions to this standard (alphabetically):~~

- ~~- tbe~~

Contents	Page
1 Scope	1
2 Normative References	2
2.1 Normative references	2
2.2 Approved references	2
2.3 References under development	2
2.4 Other references	3
3 Definitions, symbols, abbreviations, and conventions	4
3.1 Definitions	4
3.2 Keywords	4
3.3 Editorial conventions	5
3.4 Feature Set table terms, definitions, and abbreviations	6
4 Structure and Concepts	7
5 Management Tool Requirements	9
5.1 Overview	9
5.2 Generic Services	9
5.2.1 Management Tool Usage	9
5.2.2 Management Tool Requirements on Other Elements	9
5.3 HBA Requirements to support the Management tool	9
6 Requirements for Hosts	12
6.1 Overview	12
6.2 Generic Services Registration	12
6.3 Requirements for initiator FCP_Ports	13
6.3.1 Overview	13
6.3.2 Initiator FCP_Port operation	14
7 Requirements for Fabrics	23
7.1 Overview	23
7.2 Generic Service requirements for a Fabric	23
7.2.1 Mandatory Name Server Features	23
7.2.2 Mandatory Fabric Configuration Server attributes and requests	24
7.2.3 Mandatory Unzoned Name Server requests	26
7.2.4 Mandatory Zone Server requests	26
7.2.5 Mandatory HBA Management Server attributes and requests	27
7.3 Switch operation	28
8 Requirements for Storage	38
8.1 Overview	38
8.2 Generic Services Registration	38
8.3 Target FCP_Port state machines	39
8.3.1 overview	39
8.3.2 Initialization state machine	41
8.3.3 PLOGI/PRLI state machine	45
8.3.4 RSCN state machine	45
8.3.5 Target internal change state machine	46

9	Requirements for an FCP_Port with initiator and target functions	48
9.1	Overview	48
9.2	Requirements	48
Annex A (Normative) Retry Rules		-49
A.1	Summary	-49
A.2	Initiator FCP_Ports or target FCP_Ports	-49
A.2.1	LS_RJT or Reject CT_IU	-49
A.2.2	Timeout	-49
A.2.3	Reject reason code handling	-49
A.2.3.1	Summary	-49
A.2.3.2	LS_RJT retryable Reason Codes	-50
A.2.3.3	Reject CT_IU retryable Reason Codes	-50
A.2.3.4	Directory Service specific Reject CT_IU retryable Reason Codes	-50

Figure		Page
1	Interoperability Architecture	7
2	Initiator FCP_Port state machine	15
3	Switch state machine	29
4	Target FCP_Port state machines	40

Table	Page
Table 1 – Numbering Conventions	6
Table 2 – Port Name Server attributes provided to Host by HBA	10
Table 3 – Fabric Configuration Server attributes provided to Host by HBA	10
Table 4 – HBA Management Server Host Bus Adapter attributes provided per port to Host by HBA11	
Table 5 – HBA Management Server Host Bus Adapter attributes provided to Host by HBA	11
Table 6 – Name Server attributes registered by Host	12
Table 7 – Fabric Configuration Server attributes registered by Host	12
Table 8 – HBA Management Server Host Bus Adapter per-port attributes registered by Host	13
Table 9 – HBA Management Server Host Bus Adapter attributes registered by Host	13
Table 10 – Name Server requests supported by Switch	23
Table 11 – Fabric Configuration Server attributes supported by Switch	24
Table 12 – Fabric Configuration Server requests supported by Switch	25
Table 13 – Zone Server Attributes supported by Switch	26
Table 14 – Zone Server requests supported by Switch	26
Table 15 – HBA Management Server Host Bus Adapter attributes supported by Switch	27
Table 16 – HBA Management Server requests supported by Switch	27
Table 17 – Name Server attributes registered by Storage Device	38
Table 18 – Fabric Configuration Server attributes registered by Storage Device	39
Table 19 – Retryable LS_RJT Reason Codes/Reason Code Explanations	50
Table 20 – Retryable Reject CT_IU Reason Codes/Reason Code Explanations	50
Table 21 – Directory Service retryable Reject CT_IU Reason Codes/Reason Code Explanations	50

1 Scope

The scope of this technical report includes all of the elements necessary to provide a small, easily manageable SAN environment. It is the intention of this technical report to provide a SAN environment that can be managed by one part-time person who is not skilled in IT management. This technical report is not oriented toward management of a large SAN by an IT department with SAN management experts. This technical report requires some features that are in the referenced ANSI/INCITS standards.

This technical report identifies the mechanisms necessary for a management tool to promote successful management of a SAN by those not skilled in the management of a SAN. An additional objective of this technical report is to simplify implementations and their associated documentation, testing, and support requirements.

This technical report is applicable only to end devices that implement the SCSI-FCP FC-4. Implementations of other FC-4 protocols are not included in the scope of this technical report.

Internal characteristics of conformant implementations are not defined by this technical report. This technical report incorporates features from the standards and technical reports described in clause 2.

2 Normative References

2.1 Normative references

The following standards contain provisions that, by reference in the text, constitute provisions of this technical report. At the time of publication, the editions indicated were valid. All standards are subject to revision, and parties to agreements based on this technical report are encouraged to investigate the possibility of applying the most recent editions of the standards listed below.

Copies of the following documents may be obtained from ANSI: approved ANSI standards, approved and draft international and regional standards (ISO, IEC, CEN/CENELEC, ITUT), and approved and draft foreign standards (including BSI, JIS, and DIN). For further information, contact ANSI Customer Service Department at 212-642-4900 (phone), 212-302-1286 (fax) or via the World Wide Web at <http://www.ansi.org>.

Additional availability contact information is provided below as needed.

2.2 Approved references

ASCII: *ISO/IEC 646:1991, Information technology - ISO 7-bit coded character set for information interchange (third edition)*

FC-AL-2: *ISO/IEC 14165-122:2005, Fibre Channel-Arbitrated Loop-2 (FC-AL-2) [ANSI INCITS 332-1999 (R2004)]*

FC-AL-2 AM1: *ANSI INCITS 332-1999/AM1-2003, Fibre Channel-Arbitrated Loop-2 (FC-AL-2) Amendment 1*

FC-FS-2: *ANSI INCITS 424-2007, Fibre Channel — Framing and Signalling, second generation (FC-FS-2)*

FC-GS-5: *ANSI INCITS 427-2007, Fibre Channel — Generic Services, fifth generation (FC-GS-5)*

FC-HBA: *ANSI INCITS 386-2004, Host Bus Adapter Tool Programming Interface (FC-HBA)*

FC-LS: *ANSI INCITS 433-2007, Fibre Channel — Link Services (FC-LS)*

FCP-2: *ANSI INCITS 350-2003, SCSI Fibre Channel Protocol - 2 (FCP-2)*

FCP-3: *ANSI INCITS 416-2006, SCSI Fibre Channel Protocol - 3 (FCP-3)*

FC-SP: *ANSI INCITS 426-2007, Fibre Channel - Security Protocol (FC-SP)*

FC-SW-4: *ANSI INCITS 418-2006, Fibre Channel — Switch Fabric - 4 (FC-SW-4)*

SM-HBA: *ANSI INCITS 428-2007, Host Bus Adapter Application Programming Interface (SM_HBA)*

2.3 References under development

At the time of publication, the following referenced standards were still under development. For information on the current status of the document, or regarding availability, contact the relevant standards body or other organization as indicated.

FC-FS-3: *ANSI INCITS xxx-200X, Fibre Channel — Framing and Signalling, third generation (FC-FS-3)*

FC-GS-6: ANSI INCITS xxx-200X, *Fibre Channel — Generic Services, sixth generation (FC-GS-6)*

FC-LS-2: ANSI INCITS xxx-200X, *Fibre Channel — Link Services, second generation (FC-LS-2)*

FCP-4: ANSI INCITS xxx-200x, *SCSI Fibre Channel Protocol - 4(FCP-4)*

FC-SW-5: ANSI INCITS xxx-200X, *Fibre Channel — Switch Fabric - 5 (FC-SW-5)*

FC-SP-2: ANSI INCITS xxx-200X, *Fibre Channel - Security Protocol, second generation (FC-SP-2)*

SM-HBA-2: ANSI INCITS xxx-200X, *Storage Management Host Bus Adapter Application Programming Interface 2nd Generation (SM-HBA-2)*

SPC-4: ANSI INCITS xxx-200x, *SCSI Primary Commands - 4 (SPC-4)*

2.4 Other references

For information on the current status of the listed document(s), or regarding availability, contact the indicated organization.

3 Definitions, symbols, abbreviations, and conventions

3.1 Definitions

3.1.1 Default Zone: As defined in FC-GS-6.

3.1.2 HBA: a combination of hardware, hardware-resident firmware, and Host-resident software that provides to a Host:

- a) at least one PN_Port;
- b) at least one VN_Port;
- c) the functions of FC-0, FC-1, FC-2, and FC-3 for the VN_Ports it provides; and
- d) the functions of at least one FC-4 for the VN_Ports it provides.

3.1.3 Host: a computing system that contains an FCP initiator, provides end user services (e.g., e-mail access) and that connects to a SAN.

3.1.4 Initial FC discovery: The process used by an N_Port compliant with this technical report to determine the 24 bit addresses and World Wide Port Names of FCP_Ports that are also compliant with this technical report.

3.1.5 Name Server Session Begin bit: As defined in FC-LS-2.

3.1.6 RSCN FC discovery: The process used by an N_Port compliant with this technical report to determine the 24 bit addresses and World Wide Port Names of FCP_Ports that are compliant with this technical report after an RSCN is received.

3.1.7 SCM environment: a SAN that is composed of devices that are compliant with this technical report.

3.1.8 SCM FC Switch: A Fibre Channel switch that is compliant with clause 7.

3.1.9 Wildcard Zone: A zone that provides any to any connectivity between FC-SCM compliant devices.

3.2 Keywords

3.2.1 invalid: A keyword used to describe an illegal or unsupported bit, byte, word, field or code value. Receipt by a device server of an invalid bit, byte, word, field or code value shall be reported as error.

3.2.2 mandatory: A keyword indicating an item that is required to be implemented as defined in this technical report.

3.2.3 may: A keyword that indicates flexibility of choice with no implied preference.

3.2.4 may not: A keyword that indicates flexibility of choice with no implied preference.

3.2.5 option, optional: Keywords that describe features that are not required to be implemented by this technical report. However, if any optional feature defined by this technical report is implemented, then it shall be implemented as defined in this technical report.

3.2.6 reserved: A keyword referring to bits, bytes, words, fields, and code values that are set aside for future standardization. A reserved bit, byte, word, or field shall be set to zero, or in accordance with a future extension to

this technical report. Recipients are not required to check reserved bits, bytes, words, or fields for zero values. Receipt of reserved code values in defined fields shall be reported as error.

3.2.7 shall: A keyword indicating a mandatory requirement. Designers are required to implement all such mandatory requirements to ensure interoperability with other products that conform to this technical report.

3.2.8 should: A keyword indicating flexibility of choice with a strongly preferred alternative.

3.2.9 vendor specific: Something (e.g., a bit, field, code value) that is not defined by this technical report. Specification of the referenced item is determined by the device vendor and may be used differently in various implementations.

3.3 Editorial conventions

Certain words and terms used in this technical report have a specific meaning beyond the normal English meaning. These words and terms are defined either in the glossary or in the text where they first appear.

Upper case is used when referring to the name of a numeric value defined in this specification or a formal attribute possessed by an entity. When necessary for clarity, names of objects, procedure calls, arguments or discrete states are capitalized or set in bold type.

In this technical report, a number of conditions, mechanisms, sequences, parameters, events, states, or similar terms are printed with the first letter of each word in upper-case and the rest lower-case (e.g., Exchange, Sequence). Any lower case uses of these words have the normal technical English meanings.

An alphanumeric list (e.g., a, b, c) of items indicate the items in the list are unordered. A numeric list (e.g., 1, 2, 3) of items indicate the items in the list are ordered (i.e., item 1 shall occur or complete before item 2).

In case of any conflict between figures, tables, and text, the text takes precedence. Exceptions to this convention are indicated in the appropriate sections.

In all of the figures, tables, and text of this document, the most significant bit of a binary quantity is shown on the left side. Exceptions to this convention are indicated in the appropriate sections.

In the various ladder diagrams that show a sequence of events, the vertical axis (i.e., up and down the page) shows time from top to bottom.

Notes and examples do not constitute any requirements for implementors.

A binary number is represented in this technical report by any sequence of digits comprised of only the Arabic numerals 0 and 1 immediately followed by a lower-case b (e.g., 0101b). Underscores or spaces may be included in binary number representations to increase readability or delineate field boundaries (e.g., 0_0101_1010b or 0_0101_1010b).

A hexadecimal number is represented in this technical report by any sequence of digits comprised of only the Arabic numerals 0 through 9 and/or the upper-case English letters A through F immediately followed by a lower-case h (e.g., FA23h). Underscores or spaces may be included in hexadecimal number representations to increase readability or delineate field boundaries (e.g., B_FD8C_FA23h or B_FD8C_FA23h).

A decimal number is represented in this technical report by any sequence of digits comprised of only the Arabic numerals 0 through 9 not immediately followed by a lower-case b or lower-case h (e.g., 25).

This technical report uses the following convention for representing decimal numbers:

- a) the decimal separator (i.e., separating the integer and fractional portions of the number) is a period;
- b) the thousands separator (i.e., separating groups of three digits in the portion of a number) is a space; and
- c) the thousands separator is used in both the integer and fractional portion of a number.

Table 1 shows some examples of decimal numbers using various conventions.

Table 1 – Numbering Conventions

French	English	This technical report
0,6	0.6	0.6
3,141 592 65	3.14159265	3.141 592 65
1 000	1,000	1 000
1 323 462,95	1,323,462.95	1 323 462.95

When the value of the bit or field is not relevant, x or xx appears in place of a specific value.

3.4 Feature Set table terms, definitions, and abbreviations

Features that some but not all of the referenced ANSI/INCITS standards require for compliance may not be referenced in this technical report and if those features are implemented they shall not be required for compliant devices to interoperate as defined in this technical report.

There may be some optional features of the referenced ANSI/INCITS standards that are not mutually exclusive, but are required for the purpose of this technical report. Each specification of such a required feature in this technical report identifies the referenced ANSI/INCITS standards in which the feature is defined.

Features in this technical report are summarized in the form of Feature Set tables. In several tables within this technical report, there are references to notes associated with the table. These notes are normative and are mandatory requirements of this technical report.

4 Structure and Concepts

This technical report defines an environment in which a compliant device adheres to a set of behaviors that allow a management tool to simply manage the SAN of which this device is a component, as shown in figure 1. The SAN consists of one or more hosts (e.g., servers), one or more switches, and one or more storage devices. The management tool may reside on one of the hosts, in one of the switches, or in one of the storage devices. This technical report presumes that changes in the SAN configuration are performed by a single management tool. If multiple management tools are operating concurrently in a single SAN, then coordination of their activities is outside the scope of this technical report.

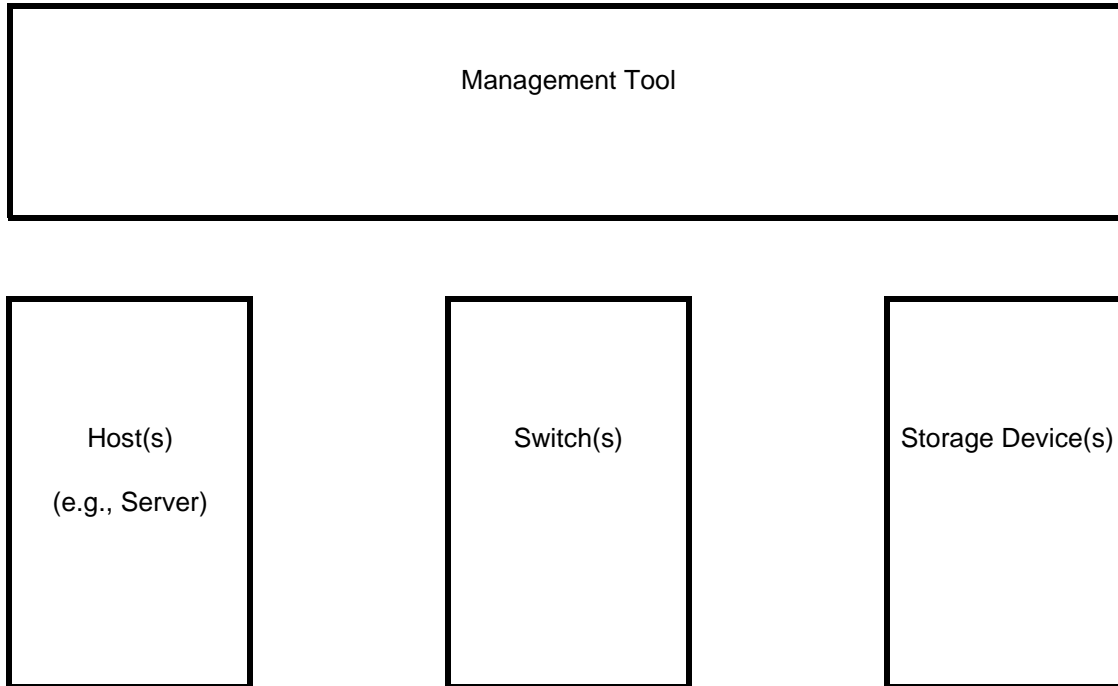

Figure 1 — Interoperability Architecture

This environment encompasses the following areas:

- a) **Management Tool Behavior:** The set of behaviors provided by a host, switch, or storage device that a management tool running locally in that host, switch, or storage device may use to manage a SCM environment;
- b) **Host Behavior:** The set of behaviors required to allow a Host, including a Host Bus Adapter, to be used to manage a SCM environment and be managed in a SCM environment;
- c) **Fabric Behavior:** The set of behaviors required to allow a Fabric to be used to manage an SCM environment and be managed in a SCM environment; and
- d) **Storage Behavior:** The set of behaviors required to allow a Storage device to be used to manage an SCM environment and be managed in a SCM environment.

Management Behavior is interrelated to all other behaviors (e.g., a Fabric is required not only to meet Fabric Behavior but Management Tool Behavior as well, or a Host is required to meet both Host Behavior and Management Tool Behavior).

The scope of this technical report is limited to defining the mechanisms necessary to promote successful management of a SAN by those not skilled in the management of a SAN. An SCM-compliant management tool may be unable to manage a SAN containing devices not compliant with this technical report.

~~N_Ports compliant with this technical report are defined as Simplified Behavior N_Ports. Simplified Behavior N_Ports shall indicate this by setting to one the Simplified Behavior bit in the FLOGI Common Service parameters (see FC-LS-2) and by registering the FC-4 TYPE-DEh and the Simplified Behavior feature bit for FC-4 TYPE-DEh in the FC Name Server (see FC-FS-3).~~ N_Ports compliant with this technical report use specific link services and generic services that facilitate discovery of FCP initiators and FCP targets through the use of the wildcard zone within switches compliant with this technical report.

5 Management Tool Requirements

5.1 Overview

The Management Tool defined in this clause is critical to achieving the goals of this technical report. The Management Tool provides a consistent, user-friendly interface to operating a SCM environment.

In addition to requirements on the Management Tool, this clause identifies which of the requirements placed on other elements of the FC-SCM model (see clause 4) arise wholly or in part from Management Tool uses.

5.2 Generic Services

5.2.1 Management Tool Usage

~~A Management Tool compliant with this report shall be capable of managing the SAN utilizing the SM-HBA function interface to Generic Services (e.g., Name Server) that is provided by the Host.~~ A Management Tool compliant with this report that utilizes a HBA shall be capable of managing the SAN utilizing the SM-HBA function interface to the Generic Services that is provided by the Host (see 5.3).

The Generic Services requests and attributes that the management tool uses shall be limited to those specified in 7.2.

5.2.2 Management Tool Requirements on Other Elements

For the management tool to be capable of managing the SAN: Switches, Hosts, and Storage devices shall register Generic Service attributes as defined in 6.2, 7.2, and 8.2

5.3 HBA Requirements to support the Management tool

To support a management tool, an HBA shall meet the compliance requirements specified in SM-HBA, and not reject the following calls for lack of support:

- a) HBA_SendCTPassThruV2;
- b) HBA_RemoveCallback;
- c) SMHBA_GetAdapterAttributes;
- d) SMHBA_GetAdapterPortAttributes;
- e) SMHBA_GetFCPhyAttributes;
- f) SMHBA_GetNumberOfPorts;
- g) SMHBA_GetPortType;
- h) SMHBA_RegisterForAdapterPortEvents;
- i) SMHBA_ScsiInquiry; and
- j) SMHBA_ScsiReportLuns.

An HBA shall provide the Name Server attributes in table 2 to the management tool for each of its ports.

Table 2 – Port Name Server attributes provided to Host by HBA

Mandatory Attribute	SM-HBA Call ^a
FC-4 TYPEs	SMHBA_GetAdapterPortAttributes
Symbolic Port Name ^b	SMHBA_GetAdapterPortAttributes
Symbolic Node Name ^b	none
Port Type	SMHBA_GetPortType
FC-4 Features	SMHBA_GetAdapterPortAttributes
<u>Port Name</u>	<u>SMHBA_GetAdapterPortAttributes</u>
<u>Port Name Server</u>	<u>none</u>
^a If an SM-HBA call is named, <u>then</u> an HBA shall provide the attribute via that call. If an SM-HBA call is not named, <u>then</u> an HBA shall provide the attribute via vendor specific means. ^b An HBA may return a null string for this attribute, indicating it has not been administratively configured.	

An HBA shall provide the Fabric Configuration Server attributes in table 3 to the management tool for each of its ports.

Table 3 – Fabric Configuration Server attributes provided to Host by HBA

Mandatory Attribute	SM-HBA Call ^a
Platform Name	none
Platform Type	none
Platform Attribute Block: Vendor ID	none
Platform Attribute Block: Product ID	none
Platform Attribute Block: Product revision level	none
Platform Attribute Block: Label	none
Platform Node Name	none
Platform Label	none
^a If an SM-HBA call is named, <u>then</u> an HBA shall provide the attribute via that call. If an SM-HBA call is not named, <u>then</u> an HBA shall provide the attribute via vendor specific means.	

An HBA shall provide the HBA Management Server Host Bus Adapter attributes in table 4 to the

management tool for each of its ports.

Table 4 – HBA Management Server Host Bus Adapter attributes provided per port to Host by HBA

<u>Mandatory Attribute</u>	<u>SM-HBA Call</u>
<u>Port State</u>	<u>SMHBA_GetAdapterPortAttributes</u>
<u>Supported Speed</u>	<u>SMHBA_GetFCPhyAttributes</u>
<u>Current Speed</u>	<u>SMHBA_GetFCPhyAttributes</u>

An HBA shall provide the HBA Management Server Host Bus Adapter attributes in table 5 to the management tool.

Table 5 – HBA Management Server Host Bus Adapter attributes provided to Host by HBA

Mandatory Attribute	SM-HBA Call ^a
HBA_Identifier	none
Manufacturer	SMHBA_GetAdapterAttributes
Serial Number	SMHBA_GetAdapterAttributes
Model	SMHBA_GetAdapterAttributes
Hardware Version	SMHBA_GetAdapterAttributes
Driver Version ^b	SMHBA_GetAdapterAttributes
Option ROM Version ^b	SMHBA_GetAdapterAttributes
Firmware Version ^b	SMHBA_GetAdapterAttributes
Number of Ports	SMHBA_GetNumberOfPorts
Boot BIOS Version ^b	SMHBA_GetAdapterAttributes
Boot BIOS State ^b	none
Registered Port List	SMHBA_GetAdapterPortAttributes
^a If an SM-HBA call is named, <u>then</u> an HBA shall provide the attribute via that call. If an SM-HBA call is not named, <u>then</u> an HBA shall provide the attribute via vendor specific means. ^b An HBA may return a null string for this attribute, indicating it is not supported.	

6 Requirements for Hosts

6.1 Overview

This clause defines the attributes that shall be registered (see 6.2) and when those attributes shall be registered (see 6.3) ~~requirements that by~~ all compliant Hosts ~~shall implement~~.

6.2 Generic Services Registration

A Host shall register the Name Server attributes in table 6 for each of its N_Ports that has completed FLOGI.

Table 6 – Name Server attributes registered by Host

Mandatory Attribute	Qualification of Registration Requirement
FC-4 TYPEs	A Host shall register an FC-4 TYPES attribute that indicates it supports: <ul style="list-style-type: none"> a) Fibre Channel Protocol (see FCP-4); and b) Generic Fibre Channel Features (see FC-GS-6).
Symbolic Port Name	A Host shall register this attribute if it has been administratively -configured for the N_Port.
Symbolic Node Name	A Host shall register this attribute if it has been administratively -configured.
FC-4 Features	A host shall register: <ul style="list-style-type: none"> a) a TYPE before it registers FC-4 Features for that TYPE; b) FC-4 Features for FCP-4 with the Initiator bit set to one; and c) Generic Fibre Channel Features with the Simplified Behavior declared feature<u>bit set to one</u>.

A Host shall register the Fabric Configuration Server attributes in table 7.

Table 7 – Fabric Configuration Server attributes registered by Host

Mandatory Attribute	Qualification of Registration Requirement
Platform Name	none
Platform Type	none
Platform Attribute Block: Vendor ID	none
Platform Attribute Block: Product ID	none
Platform Attribute Block: Product revision level	none
Platform Attribute Block: Label	A Host shall register this attribute for itself if it has been administratively -configured.
Platform Node Name	A Host shall register an instance of this attribute for each Node_Name by which at least one N_Ports of the Host is currently logged in to the Fabric.

A Host shall register the Fabric Configuration Server attributes in table 8.

Table 8 – HBA Management Server Host Bus Adapter per-port attributes registered by Host

<u>Mandatory Attribute</u>	<u>Qualification of Registration Requirement</u>
<u>Port State</u>	<u>none</u>
<u>Supported Speed</u>	<u>none</u>
<u>Current Speed</u>	<u>none</u>

A Host shall register the HBA Management Server Host Bus Adapter attributes in table 9 for each of its HBAs.

Table 9 – HBA Management Server Host Bus Adapter attributes registered by Host

Mandatory Attribute	Qualification of Registration Requirement
HBA_Identifier	none
Manufacturer	none
Serial Number	none
Model	none
Hardware Version	none
Driver Version	A Host shall register this attribute for an HBA if the HBA provides it.
Option ROM Version	A Host shall register this attribute for an HBA if the HBA provides it.
Firmware Version	A Host shall register this attribute for an HBA if the HBA provides it.
OS Name and Version	none
Number of Ports	none
Boot BIOS Version	A Host shall register this attribute for an HBA if the HBA provides it.
Boot BIOS State	A Host shall register this attribute for an HBA if the HBA provides it.
Registered Port List	none

6.3 Requirements for initiator FCP_Ports

6.3.1 Overview

This clause defines requirements that all initiator FCP_Ports shall implement.

Initiator FCP_Ports shall implement the Initiator FCP_Port state machine (see 6.3.2) that includes the following:

- a) set the Name Server Session Begin bit in the FLOGI request (see FC-LS-2);
- b) not transmit Request CT_IUs ([see FC-GS-6](#)) to any of the Well Known Addresses for reasons other than the ones specified in 6.3.2 [in any state other than state IN10: Normal Operation state](#);
- c) register FC-4 Types using RFT_ID (see 6.3.2);
- d) register FC-4 Features using RFF_ID (see 6.3.2);

- e) register Symbolic Port Name using RSPN_ID if one is configured (see 6.3.2);
- f) register Symbolic Node Name using RSNN_NN if one is configured (see 6.3.2);
- g) register for state change by transmitting a State Change Registration (SCR) ELS Request;
- h) use only the GPN_SDFCP Request CT_IU specifying an FCP target function supported for SCM Initial FC discovery (see 6.3.2);
- i) use either GPN_SDFCP Request CT_IU or GPN_ID Request CT_IUs (i.e. not both) after RSCN reception (see 6.3.2); and
- j) be capable of ~~operation~~ implementing the state machine in 6.3.2 using only the Request CT_IUs listed in table 10 and table 12.

An initiator FCP_Port that makes a transition not allowed by this state machine may be placed in the Fenced state by the Switch that the port is attached to.

6.3.2 Initiator FCP_Port operation

The initiator FCP_Port state machine is shown in figure 2. This state machine defines the interactions of an initiator FCP_Port with FC Switches and other N_Ports in the Wildcard Zone. The state machine is not intended to replace other state machines defined in other Fibre Channel standards but it is intended to prohibit certain behaviors allowed by those state machines

Figure 2 — Initiator FCP_Port state machine

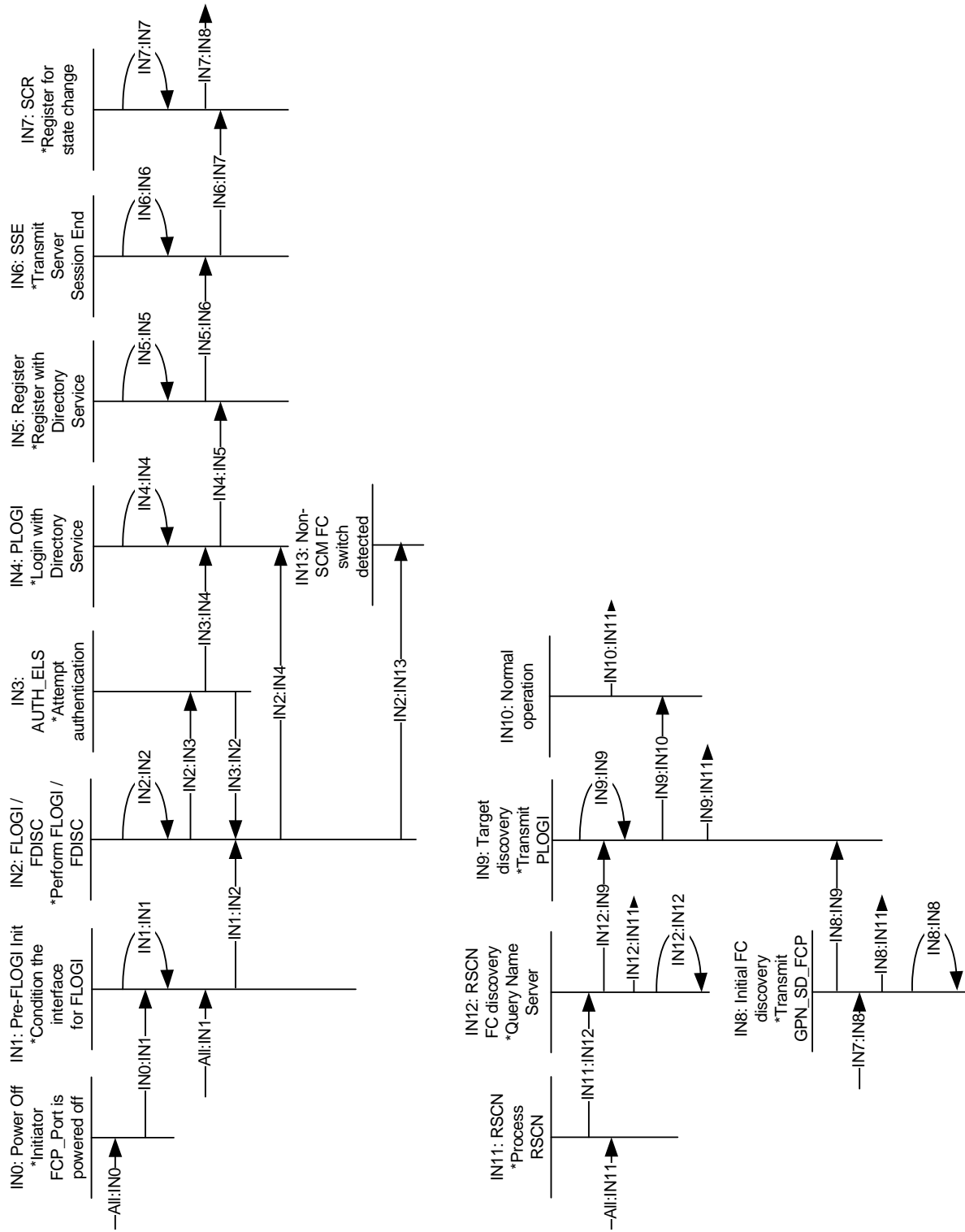

State IN0: Power off. The initiator FCP_Port is powered off.

Transition All:IN0. If the initiator FCP_Port is powered off, then the initiator FCP_Port shall transition to state IN0.

Transition IN0:IN1. If the initiator FCP_Port is powered on, then the initiator FCP_Port shall transition to state IN1.

State IN1: Link Init. Pre-FLOGI Init. The initiator FCP_Port shall:

- a) Perform Link Initialization, as defined by the Link Initialization protocol clause in FC-FS-3, with one exception; initiator FCP_Ports do not support Arbitrated Loop and do not attempt Loop initialization as outlined in FC-AL-2; or
- b) Perform ENode/FCF Discovery if required, as defined in FC-BB-5. Link Initialization, as defined by the Link Initialization protocol clause in FC-FS-3, executes while in this state with one exception; initiator FCP_Ports do not support Arbitrated Loop and do not attempt Loop initialization as outlined in FC-AL-2.

~~During Link Initialization, an initiator FCP_Port shall not complete link initialization until it is capable of completing the Login and Registration process. An initiator FCP_Port that repeatedly performs the Link Initialization protocol to the Active state may be placed in the Fenced state by the Switch that the port is attached to. Refer to transition to P0 in 7.3.~~

Transition All:IN1. The initiator FCP_Port shall transition to state IN1 if:

- a) an Initialization event occurs, as defined in FC-FS-3;
- b) the initiator FCP_Port detects that its physical layer is not operational as defined in FC-BB-5; or
- c) the initiator FCP_Port detects a non-local fault as defined in FC-BB-5 (e.g. unsolicited multicast Discovery Advertisements are not received within $2.5 * FKA_ADV_PERIOD$)~~If an Initialization event occurs as defined in FC-FS-3, then the initiator FCP_Port shall transition to state IN1.~~

Transition IN1:IN1. If the Link initialization protocol as defined in FC-FS-3 was not successful within R_T_TOV, ~~then the~~ the initiator FCP_Port shall ~~remain in~~transition to State IN1 and retry the Link Initialization protocol.

Transition IN1:IN2. If link Initialization has been completed and the initiator FCP_Port has reached the Active state as defined in FC-FS-3, then the initiator FCP_Port shall transition to state IN2.

State IN2: FLOGI/FDISC. Fabric Login as defined in FC-LS-2 shall be performed. The Name Server Session Begin (NSSB) bit (i.e., Word 1 bit 26 of the Common Service Parameters) shall be set to one. In addition to what is defined in FC-LS-2, the following additional requirements shall apply:

- a) A FLOGI ELS Request shall be transmitted within E_D_TOV of the initiator FCP_Port reaching the Active state;
- b) If an LS_ACC was received in response to the FLOGI ELS Request and an additional N_Port_ID is required, then the initiator FCP_Port shall transmit an FDISC ELS Request. Each Fabric Login requested by FDISC shall set the NSSB bit to one; and
- c) If the FLOGI ELS Request was completed by other than LS_ACC, then refer to annex Annex A.

Transition IN2:IN2. The initiator FCP_Port shall transition to state IN2 if:

- a) link initialization protocol, as defined in FC-FS-3, is completed;
- b) ENode/FCF Discovery, as defined in FC-BB-5, has discovered at least one FCF; or
- c) the initiator FCP_Port does not set the security bit to one in the FLOGI ELS Request and the Fabric returns an FLOGI LS_RJT as defined in FC-SP-2 because the Fabric requires authentication.~~If the FLOGI ELS~~

~~Request was completed by other than LS_ACC, then the initiator FCP_Port shall follow the procedure defined in annex Annex A and shall remain in State IN2.~~

Transition IN2:IN3. If the initiator FCP_Port set the security bit to one in the FLOGI ELS Request and the FLOGI LS_ACC also has the security bit set to one, then the initiator FCP_Port shall transition to state IN3.

Transition IN2:IN4. If the initiator FCP_Port did not set the security bit to one in the FLOGI ELS Request and the security bit is not set to one FLOGI LS_ACC, then the initiator FCP_Port shall transition to state IN4.

~~**Transition IN2:IN13.** If the initiator FCP_Port does not set the security bit to one in the FLOGI ELS Request and the Fabric returns an FLOGI LS_RJT as defined in FC-SP-2 because the Fabric requires authentication, then the initiator FCP_Port shall transition to state IN13.~~

Transition IN2:IN13⁴. If the Name Server Session Started~~Begin~~ bit (see FC-LS-2) was not set in the FLOGI LS_ACC, then the initiator FCP_Port shall transition to state IN13⁴.

State IN3: AUTH_ELS. Authentication shall be performed as defined in FC-SP-2.

~~**Transition IN3:IN3.** If authentication does not complete within the timeout value defined in FC-SP-2, then the initiator FCP_Port shall remain in state IN3.~~

Transition IN3:IN2. If FC-SP-2 requires the initiator FCP_Port to perform fabric login, then the initiator FCP_Port shall transition to state IN2.

Transition IN3:IN4. If authentication as defined in FC-SP-2 was successful, then the initiator FCP_Port shall transition to state IN4.

~~**Transition IN3:IN13.** If authentication as defined in FC-SP-2 was unsuccessful and a vendor-specific number of retries have been attempted, then the initiator FCP_Port shall transition to state IN13.~~

~~**Transition IN3:IN14.** If authentication as defined in FC-SP-2 was unsuccessful, then the initiator FCP_Port shall transition to state IN14.~~

State IN4: PLOGI. As defined in FC-GS-6, the initiator shall perform login with the Directory Service.

Transition IN4:IN4. If an LS_ACC was not received in response to the PLOGI ELS Request, then the initiator FCP_Port shall follow the procedure defined in annex Annex A and ~~remain in~~transition to State IN4.

Transition IN4:IN5. If a PLOGI LS_ACC from the Directory Service ~~has been~~is received, then the initiator FCP_Port shall transition to state IN5.

State IN5: Register. The initiator FCP_Port shall register with the Name Server by using the following CT_IU Requests:

- 1) Register FC-4 Type (RFT_ID) as defined in FC-GS-6. The FC-4 Types being registered shall include SCSI-FCP and Generic Fibre Channel Features;
- 2) Register FC-4 Feature (RFF_ID) as defined in FC-GS-6. The FC-4 Feature being registered for the SCSI-FCP FC-4 Type shall include Initiator (i.e., 01h) as defined in FCP-4; and
- 3) Register FC-4 Feature (RFF_ID) as defined in FC-GS-6. The FC-4 Feature being registered for the Generic Fibre Channel Features Type shall include Simplified Behavior declared.

The initiator FCP_Port ~~should~~shall register the Symbolic Node Name, if configured, and the Symbolic Port Name, if configured, with the Name Server by using the following CT_IU Requests:

- a) Register Symbolic Port Name (RSPN_ID) as defined in FC-GS-6;

NOTE 1 - The type of information contained within the Symbolic Port Name is undefined. The intent is that the information be meaningful when displayed to an administrator;

and

- b) Register Symbolic Node Name (RSNN_NN) as defined in FC-GS-6.

NOTE 2 - The type of information contained within the Symbolic Node Name is undefined, but it should be identical across all interfaces connected to the same host platform. The intent is that the information be meaningful when displayed to an administrator.

~~If the response to the Name Server registration commands is something other than an Accept CT_IU, refer to annex Annex A.~~

Transition IN5:IN5. If the RFT_ID Name Server command or either RFF_ID Name Server Commands completed by other than LS_ACC, then the initiator FCP_Port shall follow the procedure defined in annex A and shall transition to state IN5.~~If the GPN_SDFCP_SD_FCP Name Server command completed by other than LS_ACC, then the initiator FCP_Port shall follow the procedure defined in annex Annex A and shall remain in state IN5.~~

Transition IN5:IN6. ~~If all of the Name Server requests defined in state IN5 completed successfully,~~If the RFT_ID Name Server command and both RFF_ID Name Server commands completed successfully, then the initiator FCP_Port shall transition to state IN6.

State IN6: SSE. Initiator FCP_Ports shall transmit Server Session End (see FC-GS-6) to the Well Known Address of FFFFCh.

~~**Transition IN6:IN7.** If an Accept CT_IU was received in response to the Server Session End transmitted in this state, then the initiator FCP_Port shall transition to state IN7.~~

Transition IN6:IN6. If the Server Session End request completed by other than LS_ACC, then the initiator FCP_Port shall follow the procedure defined in annex Annex A and shall ~~remain in~~transition to state IN6.

Transition IN6:IN7. If an Accept CT_IU was received in response to the Server Session End transmitted in this state, then the initiator FCP_Port shall transition to state IN7.

State IN7: SCR. Initiator FCP_Ports shall register for state change by transmitting a State Change Registration (SCR) ELS Request to the Fabric Controller at address FFFFFDh as defined in FC-LS-2. The type of registration requested shall be Full registration(i.e., 03h).

Transition IN7:IN7. If the SCR ELS Request was completed by other than LS_ACC, then the initiator FCP_Port shall follow the procedure defined in annex Annex A and ~~remain in~~transition to State IN7.

Transition IN7:IN8. If an LS_ACC was received in response to the SCR ELS Request, then the initiator FCP_Port shall transition to state IN8.

State IN8: Initial FC discovery. The initiator FCP_Ports shall transmit a Get Port Names - Simplified Discovery for FCP (GPN_SDFCP) Request CT_IU as defined in FC-GS-6 to perform initial discovery of available pairings of N_Port_Names and N_Port_IDs. The FC-4 Type specified shall be SCSI FCP (08h), the Target function selection

bit shall be set to one, and the Initiator function selection bit may be set to one. The Domain_ID scope field, Area_ID scope field, and Area_ID flag shall be set to zero.

Transition IN8:IN8. If the GPN_SDFCP Request was completed by other than an Accept CT_IU, ~~then F~~ the initiator FCP_Port shall ~~remain in~~ follow the procedure defined in annex Annex A and transition to State IN8 ~~after following the procedure defined in annex Annex A.~~

Transition IN8:IN9. If an Accept CT_IU is received in response to the GPN_SDFCP ~~FF~~ Request CT_IU (see FC-GS-6), then the initiator FCP_Port shall transition to state IN9.

Transition IN8:IN11. If an RSCN ELS Request is received, then the initiator FCP_Port shall transition to state IN11.

State IN9: Target discovery. The Initiator FCP_Port logical unit discovery as defined in this state shall be used by initiator FCP_Ports for discovering and authenticating target FCP_Ports in a Fabric switch environment. This discovery process is not intended to be used following a Fabric event such as the reception of an Registered State Change Notification (RSCN).

Initiator FCP_Port logical unit discovery:

- 1) For each Port Identifier discovered via the Name Server, the Initiator FCP_Port shall:
 - 1) perform Port Login; and
 - 2) perform authentication if required (see FC-SP-2);
- 2) For each target FCP_Port that accepted the PLOGI ELS and, if required, performed authentication successfully (see FC-SP-2), perform Process Login, with the Enhanced discovery bit set to one (see FCP-4);

NOTE 3 - An initiator FCP_Port may be configured by means not defined in this technical report to not set the Enhanced discovery bit. An example of when this would need to be done is when an in-band management application needs to access a previously unconfigured target FCP_Port.

- 3) if the PRLI ELS is accepted, then the initiator FCP_Port shall record the target FCP_Port as a previously discovered FCP_Port;
- 4) if the PRLI ELS is rejected with a reason code "Unable to perform command requested" (i.e., 09h) and reason code explanation "No resources assigned" (i.e., 52h), then the initiator FCP_Port shall record the target FCP_Port as a previously discovered FCP_Port and transmit a LOGO ELS to the target FCP_Port;
- 5) if the PRLI ELS is accepted, then the initiator FCP_Port shall issue a REPORT LUNS command to LUN 0 or to the REPORT LUNS well known logical unit, to obtain a list of the logical units accessible through the target FCP_Port (see SPC-4);
- 6) if the REPORT LUNS command succeeds, then the initiator FCP_Port shall issue an INQUIRY command for each reported LUN to determine the type of peripheral device and supported command set for the logical unit (see SPC-4); and
- 7) if the INQUIRY command to determine device type succeeds, then the initiator FCP_Port shall issue an INQUIRY command with the EVPD bit set to one and the PAGE CODE set to 83h for each reported LUN to obtain the logical unit's Worldwide_Name. This allows higher level applications to identify possible redundant paths to a logical unit (see SPC-4); and
- 8) if any ELS or command in this list of actions fails, then the initiator FCP_Port shall issue a LOGO ELS to the target FCP_Port (see FC-LS-2);

NOTE 4 - The Node_Name and Port_Name are Name_Identifiers and are Worldwide_Names, assuring that they are uniquely identifiable. Logical units are also assigned a Worldwide_Name that may be examined using the

INQUIRY command with the EVPD bit set to one and the PAGE CODE set to 83h (i.e., the Device Identification VPD page) (see SPC-4)

Transition IN9:IN9. If a target FCP_Port did not respond to or rejected the PLOGI or PRLI, then the initiator FCP_Port shall follow the procedure defined in annex Annex A and shall ~~remain in~~transition to State IN9.

NOTE 5 - This transition applies only to target FCP_Ports that either did not respond to or rejected the PLOGI or PRLI. The initiator FCP_Port may continue with the discovery process with other target FCP_Ports that did respond to or accept the PLOGI or PRLI.

Transition IN9:IN10. For each target FCP_Port that returned an LS_ACC to the PRLI ELS Request, the target FCP_Port shall transition to State IN10 and initiate normal operation with that target FCP_Port.

Transition IN9:IN11. If an RSCN ELS Request is received, then the initiator FCP_Port shall transition to state IN11.

State IN10: Normal operation. The initiator FCP_Port may issue SCSI commands.

Transition IN10:IN11. If an RSCN ELS Request is received, then the initiator FCP_Port shall transition to state IN11.

State IN11: RSCN. The initiator FCP_Port has received an RSCN ELS Request and shall transmit an LS_ACC.

Transition IN11:IN12. If the initiator FCP_Port transmitted LS_ACC in response to the RSCN ELS Request, then the initiator FCP_Port shall transition to state IN12.

State IN12: RSCN FC discovery. After an RSCN is received the initiator FCP_Port shall:

- 1) perform one of the following actions depending upon the RSCN affected Port_ID pages:
 - a) if there is only one page in the RSCN and the address format is Port Address format, then Transmit one Get Port Name (GPN_ID) Request CT_IU as defined in FC-GS-6 to the Name Server specifying the 24 bit address of the affected port ID in the RSCN;
 - b) if there is only one page in the RSCN and the address format is Domain Address Group format, then Transmit Get Port Names (GPN_SDFCP) as defined in FC-GS-6 to perform initial discovery of available 24 bit addresses. The FC-4 Feature shall be Target (01h). The Domain ID scope shall be equal to the value of the Domain in the RSCN and Area ID scope shall be set to zero;
 - c) if there is only one page in the RSCN and the address format is Area Address Group format, then Transmit Get Port Names (GPN_SDFCP) as defined in FC-GS-6 to perform initial discovery of available 24 bit addresses. The FC-4 Feature shall be Target (01h). The Domain ID scope shall be equal to the value of the Domain in the RSCN and Area ID scope shall be equal to the Area ID scope in the RSCN;
 - d) if there is only one page in the RSCN and the address format is Fabric Address Group format, then Transmit Get Port Names (GPN_SDFCP) as defined in FC-GS-6 to perform initial discovery of available 24 bit addresses. The FC-4 Feature shall be Target (01h). The Domain ID scope shall set to zero and Area ID scope shall be set to zero; and
 - e) if there is more than one page in the RSCN, then Transmit Get Port Names (GPN_SDFCP) Request CT_IUs as defined in FC-GS-6 to perform initial discovery of available 24 bit addresses. The FC-4 Feature shall be Target (01h). The Domain ID scope shall be set zero and Area ID scope shall be set zero;
- 2) perform the following actions:
 - a) for any target FCP_Port that the initiator FCP_Port has previously discovered, if the FCP_Port was not an affected N_Port of the RSCN, then the initiator FCP_Port shall not perform discovery as defined in state IN9;

- b) for any target FCP_Port that the initiator FCP_Port has previously discovered, if the FCP_Port was an affected N_Port of the RSCN, then if:
- A) the RSCN contains an Event Qualifier of CHANGED PORT ATTRIBUTE (see FC-LS-2), then:
- 1)if the initiator FCP_Port does not have an active N_Port Login with the target FCP_Port, then, the Initiator FCP_Port shall:
 - 1)perform N_Port Login; and
 - 2)if N_Port Login succeeds, then perform authentication if required (see FC-SP-2);
 - 2)if the initiator FCP_Port has an active N_Port Login with the target FCP_Port, then perform Process Login, with the Enhanced discovery bit set to one and the Establish Image Pair bit set to one (see FCP-4);

NOTE 6 - An initiator FCP_Port may be configured by means not defined in this technical report to not set the Enhanced discovery bit. An example of when this would need to be done is when an in-band management application needs to access a previously unconfigured target FCP_Port.

- 3)if the PRLI ELS is rejected with a reason code "Unable to perform command requested" (i.e., 09h) and reason code explanation "No resources assigned" (i.e., 52h), then the initiator FCP_Port shall record the target FCP_Port as a previously discovered FCP_Port;

NOTE 7 - A target FCP_Port that has been discovered and sent a LS_RJT with Reason code "unable to perform command requested" and reason of "No resources assigned" to a PRLI, is a target FCP_Port without resources for the requesting initiator FCP_Port.

- 4)if the PRLI ELS is accepted, then the initiator FCP_Port shall record the target FCP_Port as a previously discovered FCP_Port;
- 5)if the PRLI ELS is accepted, then the initiator FCP_Port shall issue a REPORT LUNS command to LUN 0 or to the REPORT LUNS well known logical unit, to obtain a list of the logical units accessible through the target FCP_Port (see SPC-4);
- 6)if the REPORT LUNS command succeeds, then the initiator FCP_Port shall issue an INQUIRY command for each reported LUN to determine the type of peripheral device and supported command set for the logical unit (see SPC-4); and
- 7)if the INQUIRY command to determine device type succeeds, then the initiator FCP_Port shall issue an INQUIRY command with the EVPD bit set to one and the PAGE CODE set to 83h for each reported LUN to obtain the logical unit's Worldwide_Name. This allows higher level applications to identify possible redundant paths to a logical unit (see SPC-4);
- 8)if any ELS or command in this list of actions fails, then the initiator FCP_Port shall issue a LOGO ELS to the target FCP_Port (see FC-LS-2);

or

- B) the RSCN contains an Event Qualifier other than CHANGED PORT ATTRIBUTE (see FC-LS-2), then for each target FCP_Port that has successfully completed login and authentication if required, the initiator FCP_Port shall transmit **A**PDISC to the target FCP_Port and if the response to **A**PDISC is:
- a)an LS_ACC with the same parameters that were received in the previous PLOGI with that FCP_Port, then the initiator FCP_Port shall not perform any discovery; or
 - b)other than an LS_ACC with the same parameters that were received in the previous PLOGI with that FCP_Port, then the initiator FCP_Port shall perform discovery as defined in state IN9;

- c) for any target FCP_Port that is returned by the Name Server, if the initiator FCP_Port has not previously discovered the target FCP_Port, then the initiator FCP_Port shall perform discovery as defined in state IN9; and
- d) for any target FCP_Port that the initiator FCP_Port has previously discovered, if that target FCP_Port is no longer present in the Name Server as a FCP_Port, then the initiator FCP_Port shall wait R_A_TOV. and if the Port ID/WWPN combination is not rediscovered within R_A_TOV, then the initiator FCP_Port shall implicitly logout from that target FCP_Port and terminate all open exchanges with that target FCP_Port.

~~Transition IN12:IN9. If RSCN FC Discovery completed, then the initiator FCP_Port shall transition to state IN9~~

Transition IN12:IN9. For each target FCP_Port for which RSCN FC Discovery does not complete successfully the initiator FCP_Port shall transition to state IN9.

Transition IN12:IN10. For each target FCP_Port for which RSCN FC Discovery completed successfully the initiator FCP_Port shall transition to state IN10.

Transition IN12:IN11. If an RSCN ELS Request is received, then the initiator FCP_Port shall transition to state IN11.

Transition IN12:IN12. If RSCN FC Discovery did not complete, then the initiator FCP_Port shall follow the procedure defined in annex Annex A and shall ~~remain in~~transition to State IN12.

~~**State IN13: Auth fail**—An initiator FCP_Port is in this state if authentication failed.~~

~~**Transition IN13:IN1. If:**~~

- a) ~~a transition through the Loss of Signal or Loss of Synchronization states as defined in FC-FS-3 has been performed; or~~

~~NOTE 8 - The intention of this transition is to allow for a state reset (i.e., an initiator FCP_Port is not expected to retain state across link failure conditions.)~~

- b) ~~a change to the authentication configuration of the Switch has been made;~~

~~then the initiator FCP_Port shall transition to state IN1.~~

~~**Transition IN13:IN2. If:**~~

- a) ~~A change in the initiator FCP_Ports internal configuration results in support of the authentication protocol;~~
~~or~~
- b) ~~A change in the N_Ports internal configuration has been made to the initiator FCP_Port that may result in authentication being successful;~~

~~then the initiator FCP_Port shall transition to state IN2.~~

State IN134: Non-SCM switch - A switch that is not compliant with this technical report was detected and the initiator FC_Port may perform discovery of target FCP_Ports by a means not defined within this technical report.

7 Requirements for Fabrics

7.1 Overview

This clause defines requirements that all compliant Fabrics shall implement.

A Fibre Channel switch shall:

- a) not allow shared resources to be disproportionately consumed by one or more N_Ports or E_Ports that are transmitting ELS Requests or Request CT_IUs (see FC-GS-6) to any of the Well Known Addresses for reasons other than the ones specified in 6.3.2 or 8.3;
- b) support the Name Server Session Begin (NSSB) bit (i.e., Word 1 bit 27 of the Common Service Parameters) in the FLOGI ELS Request as defined in FC-LS-2;
- c) support the Wildcard Zone Member Type as defined in FCP-4FC-GS-6; and
- d) generate RSCNs to N_Ports based on FC-4 Feature type.

7.2 Generic Service requirements for a Fabric

7.2.1 Mandatory Name Server Features

All Switches shall support registering with and querying a Name Server. A Switch shall support at least 256 entries in its Name Server database. A Switch shall support the Name Server requests in table 10. This table includes requests required for support of management tools (see 5.2.1).

Table 10 – Name Server requests supported by Switch (part 1 of 2)

Mandatory Request
Get Port Name (GPN_ID)
Get Node Name (GNN_ID)
Get FC-4 TYPEs (GFT_ID)
Get Symbolic Port Name (GSPN_ID)
Get Fabric Port Name (GFPN_ID)
Get FC-4 Features (GFF_ID)
Get Port Identifier (GID_PN)
Get Port Names (GPN_NN)
Get Symbolic Node Name (GSNN_NN)
Get Port Names (GPN_FT)
Get Node Names (GNN_FF)
Get Port Names (GPN_FF)
Get Permanent Port Name - Port Identifier (GPPN_ID)
Get Port Names - Simplified Discovery for FCP (GPN_SDFCP)

Table 10 – Name Server requests supported by Switch (part 2 of 2)

Mandatory Request
Register FC-4 TYPEs (RFT_ID)
Register Symbolic Port Name (RSPN_ID)
Register FC-4 Features (RFF_ID)
Register Symbolic Node Name (RSNN_NN)

7.2.2 Mandatory Fabric Configuration Server attributes and requests

All Switches shall support registering with and querying a Fabric Configuration Server. A Switch shall support at least 256 entries in its Fabric Configuration Server database. There shall be a mechanism to determine the size of the database that each component supports.

A Switch shall support the Fabric Configuration Server attributes in table 11. This table includes attributes required for support of management tools (see 5.2.1).

Table 11 – Fabric Configuration Server attributes supported by Switch

Mandatory Attribute	Qualification of Registration Requirement
Interconnect Element Name	A Switch shall implicitly register this attribute for itself.
Interconnect Element Type	A Switch shall implicitly register this attribute for itself.
Interconnect Element Domain Identifier	A Switch shall implicitly register this attribute for itself.
Interconnect Element Fabric Name	A Switch shall implicitly register this attribute for itself.
Interconnect Element Logical Name	A Switch shall implicitly register this attribute for itself if it has been administratively configured.
Interconnect Element Information List: Vendor Name	A Switch shall implicitly register this attribute for itself.
Interconnect Element Information List: Model name/Number	A Switch shall implicitly register this attribute for itself.
Interconnect Element Information List: Release code	A Switch shall implicitly register this attribute for itself.
Port Name	A Switch shall implicitly register this attribute for each of its FC_Ports.
Attached Port Name	A Switch shall implicitly register this attribute for a) each of its F_Ports that has completed FLOGI LS_ACC; and b) each of its E_Ports that has completed E_Port initialization.
Port State	A Switch shall implicitly register this attribute for each of its FC_Ports.
Port Speed Capabilities	A Switch shall implicitly register this attribute for each of its FC_Ports.
Port Operating Speed	A Switch shall implicitly register this attribute for each of its FC_Ports that has completed link initialization.

A Switch shall support the Fabric Configuration Server requests in table 12. This table includes requests required for support of management tools (see 5.2.1).

Table 12 – Fabric Configuration Server requests supported by Switch

Mandatory Request
Get Interconnect Element List (GIEL)
Get Interconnect Element Type (GIET)
Get Interconnect Element Domain Identifier (GDID)
Get Interconnect Element Fabric Name (GFN)
Get Interconnect Element Logical Name (GIELN)
Get Interconnect Element Information List (GIEIL)
Get Port List (GPL)
Get Attached Port Name List (GAPNL)
Get Port State (GPS)
Get Port Speed Capabilities (GPSC)
Get Platform Node Name List (GPLNL)
Get Platform Type (GPLT)
Get PLATFORM Attribute Block (GPAB)
Get Platform Name - Node Name (GNPL)
Get Platform Name List (GPNL)
Register Interconnect Element Logical Name (RIELN)
Register Platform (RPL)
Register Platform Node Name (RPLN)
Register Platform Type (RPLT)
Register Platform Attribute Block (RPAB)
Deregister Platform (DPL)
Deregister Platform Node Name (DPLN)
Deregister Platform Attribute Block (DPAB)
De-Register All Platform Information (DPALL)

7.2.3 Mandatory Unzoned Name Server requests

All Switches shall provide support for registering with and querying an Unzoned Name Server. A Switch shall support at least 256 entries in its Unzoned Name Server database. There shall be a mechanism to determine the size of the database that each Switch supports.

A Switch shall support the attributes in table 11 and the requests in table 12 via the Unzoned Name Server. These tables include attributes and requests required for support of management tools (see 5.2.1).

7.2.4 Mandatory Zone Server requests

All Switches shall provide support for registering with and querying a Zone Server. A switch shall default its configuration to operate in Enhanced Zoning mode. A Switch shall support at least 256 zones and an active zone set. There shall be a mechanism to determine the size of the database that each Switch supports.

A Switch shall support the Zone Server attributes in table 13. This table includes attributes required for support of management tools (see 5.2.1).

Table 13 – Zone Server Attributes supported by Switch

Mandatory Attribute	Qualification of Support Requirement
Enhanced Zoning Objects.	
Zone Set Object for Active Zone Set	none
Zone Member Object	A Switch shall support zone members with Zone Member Types of Port_Name, Node_Name, and Wildcard.

A Switch shall support the Zone Server requests in table 14. This table includes requests required for support of management tools (see 5.2.1).

Table 14 – Zone Server requests supported by Switch

Mandatory Request
Session Commands
Server Session Begin (SSB)
Server Session End (SSE)
Commit Zone Changes (CMIT)
Enhanced Zoning Commands
Get Active Zone Set - Enhanced (GAZSE)
Activate Zone Set Direct - Enhanced (AZSDE)
Deactivate Zone Set - Enhanced (DZSE)

7.2.5 Mandatory HBA Management Server attributes and requests

All Switches shall provide support for registering with and querying an HBA Management Server. A Switch shall support at least 256 HBAs in its HBA Management Server database.

A Switch shall support the HBA Management Server Host Bus Adapter attributes in table 15. This table includes attributes required for support of management tools (see 5.2.1).

Table 15 – HBA Management Server Host Bus Adapter attributes supported by Switch

Mandatory Attribute
HBA_Identifier
Manufacturer
Serial Number
Model
Hardware Version
Driver Version
Option ROM Version
Firmware Version
OS Name and Version
Number of Ports
Boot BIOS Version
Boot BIOS State
Registered Port List
Port State
Supported Speed
Current Speed

A Switch shall support the HBA Management Server requests in table 16. This table includes requests required for support of management tools (see 5.2.1).

Table 16 – HBA Management Server requests supported by Switch (part 1 of 2)

Mandatory Request	Qualification of Support Requirement
Get Registered HBA List (GRHL)	none
Get HBA Attributes (GHAT)	A switch may not accept registration of attributes that are not mandatory in table 15. A switch may not return attributes that are not mandatory in table 15.
Get Registered Port List (GRPL)	none
Register HBA (RHBA)	none

Table 16 – HBA Management Server requests supported by Switch (part 2 of 2)

Mandatory Request	Qualification of Support Requirement
Register HBA Attributes (RHAT)	A switch may not accept registration of attributes that are not mandatory in table 15. A switch may not return attributes that are not mandatory in table 15.
Register Port (RPRT)	none
Deregister HBA (DHBA)	none
Deregister HBA Attributes (DHAT)	none
Deregister Port (DPRT)	none

7.3 Switch operation

The switch state machine is shown in figure 3. The purpose of the state machine is to define the set of behaviors that an FC Switch shall adhere to when interacting with:

- a) initiator FCP Ports;
- b) ~~and~~-target FCP_Ports; and
- c) ~~as well as~~ other switches

that are compliant with this Technical Report. The state machine is not intended to completely replace other state machines defined in other Fibre Channel standards but it does define certain behaviors that shall not be performed even though they are allowed by state machines in other standards.

The State Machine includes a boolean internal state machine variable Non Compliant Device Detected (NCDD) that indicates a port is transitioning to state P0 for failure to behave in accordance with the requirements of this technical report.

Figure 3 — Switch state machine

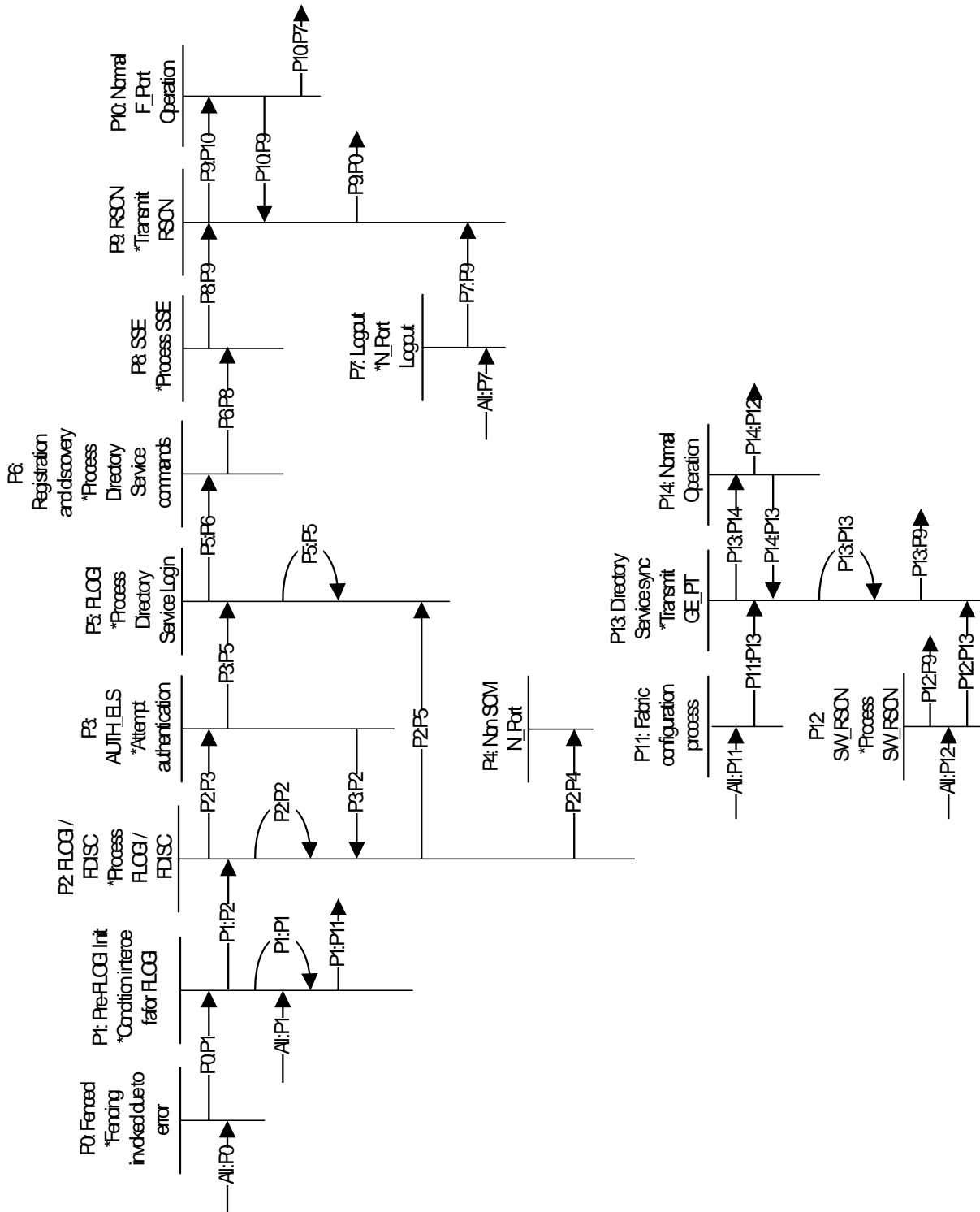

State P0: Fencing invoked due to error. A FC Switch PF Port (see FC-FS-3) or FCF VF Port (see FC-BB-5) may be in this state if the attached initiator FCP Port or target FCP Port performs an action that reduces the performance of the Switch. The switch may hold the attached initiator FCP Port or target FCP Port in State P0 for an indefinite amount of time. This action may require user intervention to resolve. In this state the FC Switch PF Port or FCF VF Port shall retain the current value of the NCDD internal state machine variable and:

- a) transmit the Offline Sequence (OLS);
- b) disable the transmitter for the PF Port that the FCP Port is connected to; or
- c) discard FIP FLOGI Requests from a particular ENode MAC.

~~A Switch port is in this state if the attached initiator FCP Port or target FCP Port performs an action that reduces the performance of the Switch. The switch may hold the attached initiator FCP Port or target FCP Port in State P0 for an indefinite amount of time. This action may require user intervention to resolve. In this state the Switch port shall retain the current value of the NCDD internal state machine variable and:~~

- ~~a) transmit the Offline Sequence (OLS); or~~
- ~~b) disable the transmitter of the optic that the FCP Port is connected to on the FC Switch.~~

Transition All:P0. If the attached N_Port is not logged into the switch and:

- a) the Link Initialization protocol as defined in FC-FS-3 is performed more than 3 times in E_D_TOV;
- b) the Switch port receives a Request and the Request is identical, not including Exchange and Sequence context, to a previous Request that has not yet been responded to and the timeout value for that request has not elapsed since the original Request was received;
- c) the Switch port receives a Request that is identical, not including Exchange and Sequence context, to a previous Request, the response to the previous Request was not LS_ACC, the reason code was retryable as specified in annex Annex A and the value of E_D_TOV has not elapsed since the original Request was received;
- d) the Switch port receives a Request that is identical, not including Exchange and Sequence context, to a previous Request, the response to the previous Request was not LS_ACC and the reason code was not retryable as specified in annex Annex A;
- e) the Switch port receives repetitive Requests and the Requests, as determined by a means not defined in this technical report, are consuming a disproportionate amount of Switch resources;
- f) the initiator FCP Port or target FCP Port performed an action not allowed by an FC standard; or
- g) other vendor specific reasons,

then the switch shall set the NCDD internal state machine variable to true on the switch port and the switch port shall transition to state P0.

NOTE 9 - Transitioning a port to state P0 may be performed by a switch port as a proactive counter measure to prevent denial of service types of attacks against the Well Known Addresses. The number of events each platform may process without negatively impacting the platform responsiveness varies from one platform to another; therefore, the number of events or the exact manner that a switch protects itself are not limited to what is defined in the state machine. The steps to recover from a proactive counter measure being invoked shall not be explicitly defined but may include the expiration of a timer, processor threshold or manual intervention to resolve the condition. Some port behaviors, especially repetitive requests, are universally considered to be detrimental to overall fabric stability and shall not be performed by initiator FCP Ports or target FCP Ports.

Transition P0:P1. The switch port may transition to state P1 if:

- a) the NCDD internal state machine variable is set to false; or
- b) the NCDD internal state machine variable is set to true and the initiator FCP Port or target FCP Port is determined to be non-defective by means not defined in this technical report and through user intervention

or some action automatically performed by the switch, the initiator FCP_Port or target FCP_Port is allowed to initialize.

Transition All:P1. If an initialization event, as defined in the Link Initialization Protocol (see FC-FS-3), is detected, then the switch port shall transition to State P1.

State P1: The switch port shall set the NCDD internal state machine variable to false and shall perform:

- a) Link Initialization, as defined by the Link Initialization protocol clause in FC FS-3, with one exception: Arbitrated Loop is not supported and Loop initialization as outlined in FC-AL-2 is not supported; or
- b) Transmit at least one FIP Advertisement as defined in FC-BB-5.

During Link Initialization, FC Switch PF Ports shall only exit the OL1 state as defined in FC-FS-3 and attempt to achieve the Active state when the switch port is capable of servicing Login and Registration requests. The FCoE Controller of a VF Port capable FCF-MAC shall only transmit FIP Advertisements when the FCF is capable of servicing Login and Registration requests.~~Link-Init. The Link Initialization Protocol as defined in FC-FS-3 is performed with one exception, a switch port may transition an attached port to State P0 for reasons defined in Transition All:P0.~~

~~During Link Initialization, Switch ports shall only exit the OL1 state as defined in FC-FS and attempt to achieve the Active state when the switch port is capable of servicing Login and Registration requests.~~

Transition P1:P1. If the Link Initialization protocol was not successful within R_T_TOV, then the switch port shall ~~remain in~~transition to State P1.

Transition P1:P2. The FC Switch PF Port or FCF VF Port shall transition to state IN2 when:

- a) the FC Switch PF Port has reached the Active state as defined in FC-FS-3; or
- b) the FCoE Controller has transmitted at least one FIP Advertisement as defined in FC-BB-5.~~If the switch port has reached the Active state as defined in FC-FS-3 and a FLOGI ELS Request is received, then the switch port shall transition to State P2.~~

Transition P1:P11~~0~~. If the FC Switch PF Port has reached the Active state and an Exchange Link Parameters (ELP) SW_ILS Request is received (see FC-SW-5), then the switch port shall transition to State P11.

~~If the switch port has reached the Active state and an Exchange Link Parameters (ELP) SW_ILS Request is received (see FC-SW-5), then the switch port shall transition to State P10.~~

If E_D_TOV has elapsed since the switch port reached the Active state and neither an FLOGI ELS Request nor ELP SW_ILS Request has been received, then the switch port shall transition to State P10 and if the switch port is capable of becoming an E_Port, then the switch port shall transmit an ELP SW_ILS Request.

State P2: FLOGI/FDISC. After receiving a FLOGI ELS Request as defined in FC-LS, the Fabric Login Server shall process the FLOGI as follows:

- 1) the Fabric Login Server shall determine if the Name Server Session Begin (NSSB) bit (i.e., Word 1, bit 26 of the Common Service Parameters) in the FLOGI ELS Request ~~has been~~is set to one and process the FLOGI ELS Request as follows:
 - A) if the bit is set to one, the FC switch shall initiate a Name Server Session (see FC-GS-6) and continue with step 2; or
 - B) if the bit is set to zero, the process for handling the FLOGI request is not defined by this technical report;

- 2) the Fabric Login Server shall determine if the security bit (i.e., Word 1, bit 21 of the Common Service Parameters) in the FLOGI ELS Request is set to one and continue with fabric login s follows:
 - A) if Authentication is required by the fabric and the security bit in the FLOGI is not set, then the FLOGI shall be rejected as defined in FC-SP-2, ~~the Name Server Session shall be terminated~~ and the Switch port shall transition to State P14;
 - B) if Authentication is supported by the N_Port but not required by the fabric, continue with step 3;
 - C) if Authentication is not required by both the attaching port as well as the Switch port, continue with step 3; or
 - D) if Authentication is required by both the attaching port as well as the Switch port, continue with step 3;
- 3) the Fabric Login Server shall transmit either:
 - A) an FLOGI LS_ACC with:
 - a) the Name Server Session Started (NSSS) bit (i.e., Word1, bit 27 of the Common Service Parameters) in the FLOGI LS_ACC is set to 1; and
 - b) the security bit set to either 0 or 1 depending upon the current configuration of the Switch port;
 - or
 - B) an LS_RJT with an appropriate reason code and reason code explanation as defined in FC-LS;
- 4) if an FLOGI LS_ACC was transmitted, the Name Server shall be automatically populated with all information contained in the FLOGI ELS Request; and
- 5) the initiator FCP_Ports or target FCP_Ports shall not be discoverable via Name Server commands nor accessible to any other FCP_Ports that are currently logged into the switch until after an accept CT_IU ~~has been~~is transmitted by the switch in response to the Server Session End (SSE) command (see State P8).

Transition P2:P2. If the response to the FLOGI:

- a) has not been transmitted within 2 x R_A_TOV and a subsequent FLOGI is received; or
- b) was an LS_RJT and a subsequent FLOGI is received.

then the switch port shall transition to State P2;~~In addition to what is defined in FC-LS-2, the following additional requirement shall apply:~~

- a) ~~after receiving an FLOGI ELS Request, reception of anything other than primitives by a switch port until a response to the FLOGI has been transmitted is unexpected unless 2 x R_A_TOV has elapsed since the FLOGI has been received. If the response to the FLOGI has not been transmitted within 2 x R_A_TOV and a second FLOGI has been received, then the switch port shall remain in State P2.~~

Transition P2:P3. If the initiator FCP_Port or target FCP_Port set the security bit (i.e., Word 1, bit 21 of the Common Service Parameters) in the FLOGI ELS Request and the switch supports authentication as defined in FC-SP-2, then the switch port shall transition to State P3.

Transition P2:P4. If the Name Server Session Begin (NSSB) bit is not set in the FLOGI ELS Request, then the switch port shall transition to State P4.

Transition P2:P5. If the initiator FCP_Port or target FCP_Port did not set the security bit (i.e., Word 1, bit 21 of the Common Service Parameters) in the FLOGI ELS Request and the switch does not require authentication, then the switch port shall transition to State P5.

State P3: Auth_ELS. Authentication shall be performed as defined in FC-SP-2.

~~**Transition P3:P3.** If a timeout occurs during authentication, then the switch port shall remain in State P3.~~

Transition P3:P2. If the switch port receives an FLOGI, then it shall transition to state P2.

Transition P3:P5. If authentication was successful, then the switch port shall transition to State P5.

~~Transition P3:P14.~~ If authentication failure as defined in FC-SP-2 occurs, then the switch port shall transition to State P14.

State P4: Non SCM N_Port. The commands and processes used by a switch to support initiator FCP Ports and target FCP_Ports that are not compliant with this technical report are not defined in this technical report.

State P5: PLOGI. In this state the switch shall process Login requests to the Name Server as defined in FC-LS-2.

Transition P5:P5. if an LS_RJT was returned in response to the PLOGI ELS Request, the response indicates a retryable condition as defined in annex Annex A, a time period of E_D_TOV has elapsed since the response was transmitted and another PLOGI ELS Request ~~has been~~is received by the switch port, then the switch port shall ~~remain in~~transition to state P5.

Transition P5:P6. If an LS_ACC was transmitted in response to the PLOGI request, then the switch port shall transition to state P6.

State P6: Registration and discovery. In addition to what is defined in FC-GS-6:

- a) switches shall respond to each Name Server Request CT_IU (see FC-GS-6) within R_A_TOV; and
- b) Registration shall be considered complete for an initiator FCP Port or target FCP_Port after an Accept CT_IU ~~has been~~is transmitted in response to the Server Session End (SSE) command.

Transition P6:P8. If a Server Session End (SSE) request was received, then the switch port shall transition to State P8.

State P7: N_Port Logout. The switch shall perform explicit or implicit Fabric logout as defined in FC-LS.

Transition All:P7. If the switch is transitioning the port to state P0 due to excessive utilization of switch resources, then the switch port shall set the NCDD internal state machine variable to true.

If the switch detects any of the following conditions:

- a) link failure;
- b) a LOGO received from the attached N_Port;
- c) transition to any of the Offline States (i.e., OL1, OL2, or OL3);
- d) transition to either of the Link Failure states (i.e., LF1 or LF2); or
- e) the switch is transitioning the port to State P0 due to excessive utilization of switch resources,

then the switch port shall transition to state P7.

Transition P7:P9. After a successful explicit or implicit Fabric logout the switch port shall transition to state P9.

State P8: SSE. In this state, the switch shall process incoming Server Session End (SSE) requests. If the SSE is addressed to the WKA of the Name Server (FFFFFCh), after transmitting the Accept CT_IU to the SSE request, the initiator FCP Port or target FCP port shall be discoverable via the Name Server and accessible to other FCP_Ports that are currently logged into the fabric as allowed by zoning~~switch~~.

Transition P8:P9. If an Accept CT_IU was transmitted in response to the SSE request, then the switch port shall transition to state P9.

State P9: RSCN. A Registered State Change Notification (RSCN) ELS Request shall be transmitted as defined in FC-LS-2 with the following restrictions:

- a) The transmission of RSCN to initiator [FCP_Ports](#) and target FCP_Ports shall depend upon zone membership, SCR usage and the registration of FC-4 Features (e.g., RSCNs shall only be transmitted to initiator FCP_Ports for target FCP_Port events and RSCNs shall only be transmitted to target FCP_Ports for initiator FCP_Port events); and
- b) RSCN usage shall be dependent upon the Event type as follows:
 - A) if the event type is Local N_Port Logout / Login or an RSCN is received from a locally attached N_Port, then an RSCN shall be generated as follows:
 - a) the Address Format shall be Port Address (i.e., 00h);
 - b) the Payload shall contain the Affected N_Port IDs; and
 - c) The RSCN shall be transmitted to the following registered N_Ports:
 - A) if the affected N_Port is not in the wildcard zone, then all N_Ports that are members of the same zone as the device for which the event has been detected;
 - B) if the affected N_Port is in the wildcard zone and has registered an FC-4 Feature of Initiator, then all N_Ports that are a member of a common zone with the affected N_Port other than the wildcard zone and all target FCP_Ports that are in the wildcard zone. (i.e., FCP_Ports that set the Name Server Session Begin (NSSB) bit in the FLOGI, registered an FC-4 Feature of Target and registered a Generic Fibre Channel Featured type of Simplified Behavior declared); or
 - C) if the affected N_Port is in the wildcard zone and has registered an FC-4 Feature of Target, then all N_Ports that are member of the same zone as the affected N_Port other than the wildcard zone and all initiator FCP_Ports that are in the wildcard zone (i.e., FCP_Ports that set the Name Server Session Begin (NSSB) bit in the FLOGI, registered an FC-4 Feature of Initiator and registered a Generic Fibre Channel Featured type of Simplified Behavior declared);
 - B) if the event type is Remote N_Port Logout / Login, then an RSCN shall be generated as follows:

NOTE 10 - The addition or removal of a remote N_Port can be detected in two ways; via SW_RSCN from the Domain containing affected N_Port or during periodic polling with GE_PT. The SW_RSCN would be the expected mechanism to for one Domain to notify another of a change in Name Server content, however, if a previously unknown N_Port is detected, or a previously known N_Port is no longer listed as a member of the name server via a response to a GE_PT, this shall have the same impact to the local name server as receiving a SW_RSCN and results in RSCN generation as described in the distribution section below.

- a) the Address Format shall be Port Address (i.e., 00h);
- b) the Payload shall contain the Affected N_Port IDs; and
- c) The RSCN shall be transmitted to the following registered N_Ports:
 - A) if the affected N_Port is not in the wildcard zone, then all N_Ports that are members of the same zone as the device for which the event has been detected;
 - B) if the affected N_Port is in the wildcard zone and has registered an FC-4 Feature of Initiator, then all N_Ports that are a member of a common zone with the affected N_Port other than the wildcard zone and all target FCP_Ports that are in the wildcard zone. (i.e., FCP_Ports that set the Name Server Session Begin (NSSB) bit in the FLOGI, registered an FC-4 Feature of Target and registered a Generic Fibre Channel Featured type of Simplified Behavior declared); or
 - C) if the affected N_Port is in the wildcard zone and has registered an FC-4 Feature of Target, then all N_Ports that are member of the same zone as the affected N_Port other than the wildcard zone and all initiator FCP_Ports that are in the wildcard zone (i.e., FCP_Ports that set the Name Server Session Begin (NSSB) bit in the FLOGI, registered an FC-4 Feature of Initiator and registered a Generic Fibre Channel Featured type of Simplified Behavior declared);

- C) if the event type is ISL addition or removal, then:
 - a) if this is the first ISL added between two separate fabrics or if this is the last ISL removed between two domains and the result is that two separate fabrics are formed, then after the Fabric Configuration process as described in FC-SW-5 has completed and a change in the domain count of the fabric is detected, an RSCN shall be generated as follows:
 - A) the address format shall be Domain Address Format (i.e., 01h);
 - B) the payload shall contain the Affected Domain ID list; and
 - C) the RSCN shall be transmitted to all N_Ports that have registered to receive Domain Address Format RSCNs;
 - and
 - b) all other ISL removals shall not generate an RSCN;
- D) and if the event type is Zone Set activation, then:
 - a) If a Zone set activation results in an increase or a decrease in the number of 24 bit addresses available to an N_Port, then an RSCN shall be generated as follows:
 - A) the address format shall be Port Address Format (i.e., 00h);
 - B) the payload shall contain the Affected N_Port ID's;
 - C) the RSCN shall be transmitted to the following registered N_Ports:
 - a) if the affected N_Port is not in the wildcard zone, then all N_Ports that are members of the same zone as the device for which the event has been detected;
 - b) if the affected N_Port is in the wildcard zone and has registered an FC-4 Feature of Initiator, then all N_Ports that are a member of a common zone with the affected N_Port other than the wildcard zone and all target FCP_Ports that are in the wildcard zone. (i.e., FCP_Ports that set the Name Server Session Begin (NSSB) bit in the FLOGI, registered an FC-4 Feature of Target and registered a Generic Fibre Channel Feature type of Simplified Behavior declared); or
 - c) if the affected N_Port is in the wildcard zone and has registered an FC-4 Feature of Target, then all N_Ports that are member of the same zone as the affected N_Port other than the wildcard zone and all initiator FCP_Ports that are in the wildcard zone (i.e., FCP_Ports that set the Name Server Session Begin (NSSB) bit in the FLOGI, registered an FC-4 Feature of Initiator and registered a Generic Fibre Channel Featured type of Simplified Behavior declared).

If the event that caused RSCN generation is:

- a) Local N_Port Logout / Login; or
- b) an RSCN received from a locally attached N_Port,

then the fabric controller shall transmit a SW_RSCN (as defined in FC-SW-5) to other Domains in the fabric if any.

NOTE 11 - While in this state, the switch continues to deliver frames to N_Ports for which a route exists.

Transition P9:P0. If the NCDD internal state machine variable is true and all RSCNs have been transmitted to the appropriate N_Ports, then the switch port shall transition to State P0.

Transition P9:P10. If the NCDD internal state machine variable is false and all RSCNs have been transmitted to the appropriate N_Ports, then the switch port shall transition to State P10.

State P10: Normal F_Port Operation. In this state the F_Port transmits and receives Frames.

Transition P10:P7. If the switch is transitioning the port to State P0 due to excessive utilization of switch resources, then the switch port shall set NCDD internal state machine variable to true.

If the switch detects any of the following conditions:

- a) link failure;
- b) a LOGO received from the attached N_Port;
- c) transition to any of the Offline States (i.e., OL1, OL2, or OL3);
- d) transition to either of the Link Failure states (i.e., LF1 or LF2); or
- e) the switch is transitioning the port to State P0 due to excessive utilization of switch resources,

then the switch port shall transition to State P7.

Transition P10:P9. If one of the conditions defined in state P8 was met that requires an RSCN to be transmitted, then the switch port shall transition to state P9.

State P11: Fabric Configuration process. Perform the Fabric Configuration process as defined in FCP-4.

Transition P11:P13. If Fabric Configuration is successful resulting in a non-isolated E_Port, then the switch port shall transition to state P13.

State P12: SW_RSCN. Transmit LS_ACC in response to the SW_RSCN Request.

Transition P12:P9. If an LS_ACC was transmitted in response to a SW_RSCN Request, then the switch port shall transition to state P9.

Transition P12:P13. If an SW_RSCN is received, then the switch port shall transition to state P13.

State P13: GE_PT Name Server Synchronization. As a part of:

- a) the fabric configuration process;
- b) the reaction to a SW_RSCN; or
- c) due to periodic polling,

GE_PT shall be used to synchronize distributed Name Server databases. Responses to GE_PT from a switch compliant with this technical report shall include FC-4 Features.

GE_PT response format:

- a) Name Server Entry Object:
 - A) The Entry Object Format Indicator shall have bit 1 set indicating the FC-4 Features are Included in the Entry Object.
 - B) The FC-4 Features array shall include the FC-4 Feature bits registered by the Initiator, Target or Multi-purpose FCP_Port.
- b) If the remote switch supports the Large Name Server object as determined via ESS, bit 0 of the Entry Format Object Indicator shall not be set to indicate that the Entry Object contains the Symbolic port Name and the Symbolic Node Name.
- c) All other fields shall be populated as specified in FC-GS-6 or FC-SW-5.

Transition P13:P9. If GE_PT is successful and a difference was detected between local and remote dNS instances, then the switch port shall transition to state P9.

Transition P13:P13. If GE_PT was not successful within R_A_TOV, then the switch port shall ~~remain in~~ transition to state P13.

Transition P13:P14. If GE_PT is successful and no difference is detected between local and remote Name Servers, then the switch port shall transition to state P14.

State P14: Normal Operation. The E_Port shall forward FC Frames in accordance with the current switch configuration.

Transition P14:P12. If a SW_RSCN is received, then the switch port shall transition to state P12.

~~**State P15: Authentication Failure**—A Switch is in this state for two reasons:~~

- ~~a) the attached initiator FCP_Port, target FCP_Port or Switch port has not set the security bit in the FLOGI/ FDISC and the Fabric requires authentication; or~~
- ~~b) authentication as defined in FC-SP-2 was unsuccessful and a vendor specific number of authentication retries had been reached.~~

~~NOTE 12 - The intention of this clause is to allow for a state reset, that is to say that it is not expected that a Switch port retains state across link failure conditions.~~

~~**Transition P15:P1.** If:~~

- ~~a) a Loss of Signal condition or Loss of Synchronization condition as defined in FC-FS-3 has occurred; or~~
- ~~b) a change to the authentication configuration of the SCM Switch has been made and the SCM Switch initiated the Link Initialization process as defined in FC-FS-3;~~

~~then the switch port shall transition to state P1.~~

~~**Transition P15:P2.** If:~~

- ~~a) a change in the Switch ports internal configuration results in support of the authentication protocol; or~~
- ~~b) a change in the Switch ports internal configuration has been made that may result in authentication being successful~~

~~then the switch port shall transition to state P2.~~

8 Requirements for Storage

8.1 Overview

This clause defines requirements that all target FCP_Ports compliant with this technical report shall implement.

Target FCP_Ports shall:

- a) set the Name Server Session Begin bit in the FLOGI (see FC-LS-2);
- b) not transmit Request CT_IUs (see FC-GS-6) to any of the Well Known Addresses for reasons other than the ones specified in 8.3, in any state other than state T9: Normal Operation state;
- c) register FC-4 Types using RFT_ID (see 8.3);
- d) register FC-4 Features using RFF_ID (see 8.3);
- e) register Symbolic Port Name using RSPN_ID if one is configured (see 8.3);
- f) register Symbolic Node Name using RSNN_NN if one is configured (see 8.3);
- g) use only the GPN_SDFCP Request CT_IU with FCP Feature selection bit 1 (initiator) set to one (see 8.3);
- h) use either GPN_SDFCP or GPN_ID Request CT_IUs (i.e. not both) after RSCN reception (see 8.3); and
- i) be capable of ~~operation~~ implementing the state machine in 8.3 using only the Request CT_IUs listed in table 10 and table 12.

8.2 Generic Services Registration

A Storage Device shall register the Name Server attributes in table 17 for each of its N_Ports that has completed FLOGI.

Table 17 – Name Server attributes registered by Storage Device

Mandatory Attribute	Qualification of Registration Requirement
FC-4 TYPEs	A Storage Device shall register an FC-4 TYPES attribute that indicates it supports: <ol style="list-style-type: none"> a) Fibre Channel Protocol (see FCP-4); and b) Generic Fibre Channel Features (see FC-GS-6).
Symbolic Port Name	A Storage Device shall register this attribute if it has been administratively configured for the N_Ports.
Symbolic Node Name	A Storage Device shall register this attribute if it has been administratively configured for the N_Ports.
FC-4 Features	A Storage Device shall register a TYPE before it registers FC-4 Features for that TYPE. A Storage Device shall register FC-4 Features for FCP-4 as follows: <ol style="list-style-type: none"> a) The Target bit set shall be to one; b) Bit 2 shall be set to one if the Storage Device acts as a Target for at least one device that is peripheral device type other than 00h (see SPC-4); c) Bit 2 shall be set to zero if the Storage Device acts as a Target for no devices that are peripheral device type other than 00h. A Storage Device shall register Generic Fibre Channel Features with the Simplified Behavior declared bit set to one.

A Storage Device shall register the Fabric Configuration Server attributes in table 18.

Table 18 – Fabric Configuration Server attributes registered by Storage Device

Mandatory Attribute	Qualification of Registration Requirement
Platform Name	none
Platform Type	none
Platform Attribute Block: Vendor ID	none
Platform Attribute Block: Product ID	none
Platform Attribute Block: Product revision level	none
Platform Attribute Block: Label	A Storage Device shall register this attribute for itself if it has been administratively configured.
Platform Node Name	A Storage Device shall register an instance of this attribute for each Node_Name by which at least one N_Ports of the Storage Device is currently logged in to the Fabric.
Platform Label	A Storage Device shall register this attribute for itself if it has been administratively configured.
<u>Platform Management Address</u>	<u>A Storage Device shall register this attribute for itself if it has been configured.</u>

8.3 Target FCP_Port state machines

8.3.1 overview

The target FCP_Port state machines are shown in figure 4 and include the following state machines:

- a) Initialization state machine;
- b) PLOGI/PRLI state machine;
- c) RSCN state machine; and
- d) Target internal change state machine.

These state machines define the interactions of a target FCP_Port with FC Switches and other FCP_Ports in the Wildcard Zone. These state machines are intended to operate in parallel and are not mutually exclusive. The state machines are not intended to replace other state machines defined in other Fibre Channel standards but are intended to prohibit certain behaviors allowed by those state machines.

Figure 4 — Target FCP_Port state machines

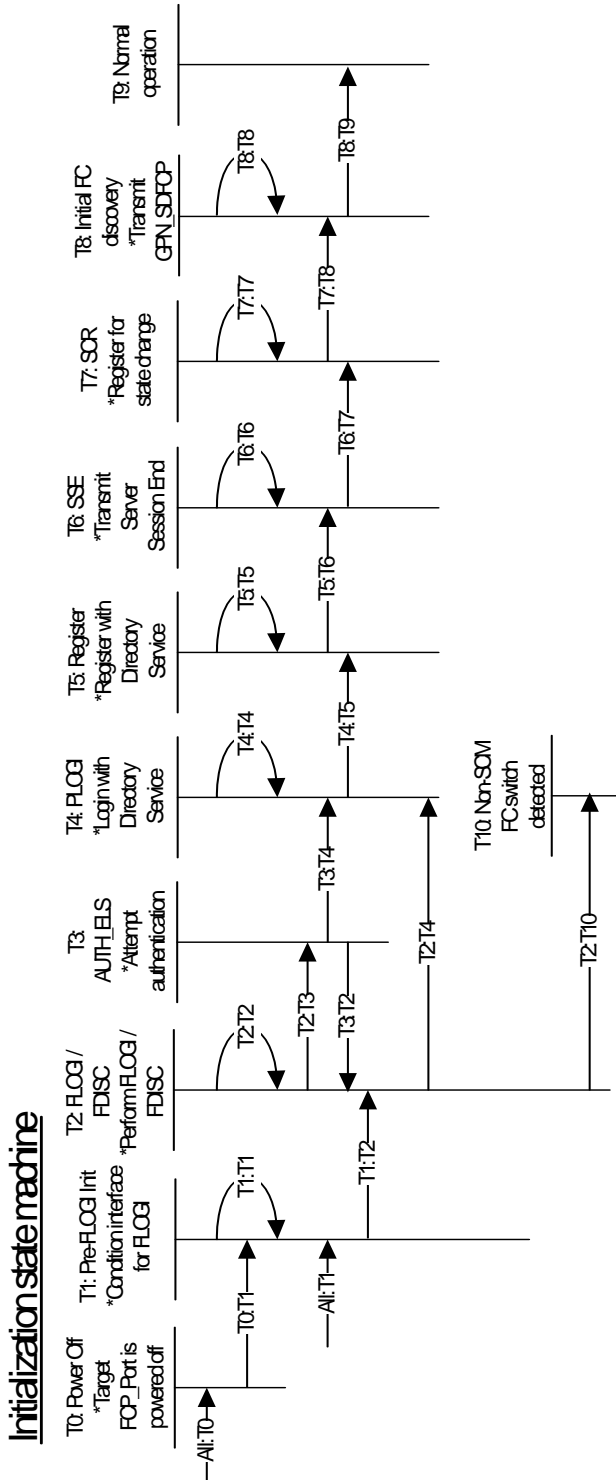

Target internal change state machine

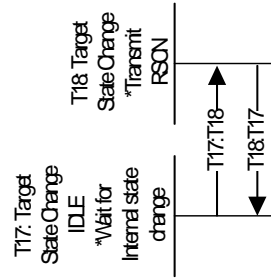

RSON state machine

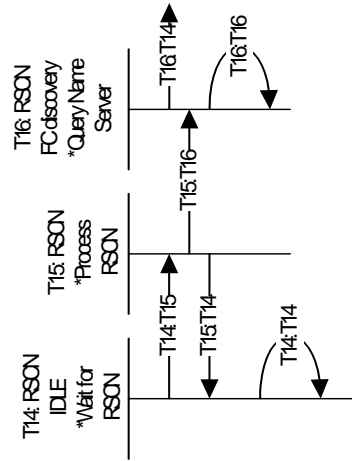

FLOG/PRJ state machine

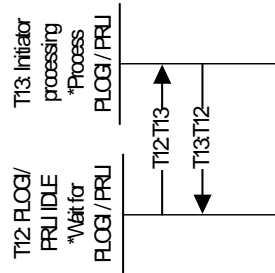

8.3.2 Initialization state machine

State T0: Power off. The target FCP_Port is powered off.

Transition All:T0. If the target FCP_Port is powered off, then the target FCP_Port shall transition to state T0.

Transition T0:T1. If the target FCP_Port is powered on, then the target FCP_Port shall transition to state T1.

State T1: Pre-FLOGI Init. The target FCP_Port shall:

- 1) de-instantiate the following state machines:
 - A) PLOGI/PRLI state machine;
 - B) RSCN state machine; and
 - C) Target internal change state machine;

and
- 2) Perform either:
 - A) Link Initialization, as defined by the Link Initialization protocol clause in FC FS-3, with one exception; target FCP_Ports do not support Arbitrated Loop and do not attempt Loop initialization as outlined in FC-AL-2; or
 - B) ENode/FCF discovery if necessary as defined in FC-BB-5.~~Link Init. The target FCP_Port shall de-instantiate the following state machines:~~
 - a) ~~PLOGI/PRLI state machine;~~
 - b) ~~RSCN state machine; and~~
 - c) ~~Target internal change state machine.~~

~~Link Initialization, as defined by the Link Initialization protocol clause in FC-FS-2, executes while in this state with one exception; target FCP_Ports compliant with this technical report do not support Arbitrated Loop and do not attempt Loop initialization as defined in FC-AL-2.~~

~~A compliant target FCP_Port shall not complete link initialization until it is capable of completing the Login and Registration process.~~

~~NOTE 13 - A target FCP_Port that repeatedly performs the Link Initialization protocol to the Active state may be placed in the Fenced state by the Switch that the port is attached to. Refer to transitioning to P0 in clause 7.~~

Transition All:T1. The target FCP_Port shall transition to state T1 if:

- a) an Initialization event occurs, as defined in FC-FS-3;
- b) upon detecting that its physical layer is not operational as defined in FC-BB-5; or
- c) upon detecting a non-local fault as defined in FC-BB-5 (e.g. unsolicited multicast Discovery Advertisements are not received within $2.5 * FKA_ADV_PERIOD$).~~If an Initialization event occurs as defined in FC-FS-2, then the target FCP_Port shall transition to state T1.~~

Transition T1:T1. The target FCP_Port shall transition to state T1 if:

- a) Link initialization protocol, as defined in FC-FS-3, was not successful within R_T_TOV; or
- b) The FCoE Initialization Protocol, as defined in FC-BB-5, was not successful.~~If the Link initialization protocol as defined in FC-FS-2 was not successful within R_T_TOV, then the target FCP_Port shall remain in State T1 and retry the Link Initialization protocol.~~

Transition T1:T2. The target FCP Port shall, transition to state T2 when:

- a) Link initialization protocol, as defined in FC-FS-3, is completed; or
- b) ENode/FCF Discovery, as defined in FC-BB-5, discovered at least one FCF.~~If Link Initialization has been completed and the target FCP_Port has reached the Active state as defined in FC-FS-2, then the target FCP_Port shall transition to state T2.~~

State T2: FLOGI/FDISC. Fabric Login as defined in FC-LS-2 shall be performed. The Name Server Session Begin (NSSB) bit (i.e., Word 1 bit 26 of the Common Service Parameters) shall be set to one. In addition to what is defined in FC-LS-2, the following additional requirements apply:

- a) a FLOGI ELS Request shall be transmitted within E_D_TOV of the target FCP_Port reaching the Active state;
- b) If an LS_ACC was received in response to the FLOGI ELS Request and one or more additional N_Port_IDs are required, then the target FCP_Port shall transmit an FDISC ELS Request with the NSSB bit (i.e., Word 1 bit 26 of the Common Service Parameters) set to one; and
- c) if the FLOGI ELS Request was completed by other than LS_ACC, then refer to annex Annex A.

Transition T2:T2. If the FLOGI ELS Request was completed by other than LS_ACC, then the target FCP_Port shall follow the procedure defined in annex Annex A and transition to state T2.

Transition T2:T3. If the target FCP_Port set the security bit to one in the FLOGI ELS Request and the FLOGI LS_ACC has the security bit set to one, then the target FCP_Port shall transition to state T3.

Transition T2:T4. If the target FCP_Port did not set the security bit to one in the FLOGI ELS Request and the security bit is not set to one the FLOGI LS_ACC, then the target FCP_Port shall transition to state T4.

~~**Transition T2:T10.** If the target FCP_Port does not set the security bit to one in the FLOGI ELS Request and the Fabric returns an FLOGI LS_RJT as defined in FC-SP because the Fabric requires authentication, then the target FCP_Port shall transition to state T10.~~

~~**Transition T2:T10+.** If the Name Server Session Started (NSSS) bit (i.e., Word 1 bit 27 of the Common Service Parameters) was set to zero in the FLOGI LS_ACC, then the target FCP_Port shall transition to state T10+.~~

State T3: AUTH_ELS. Authentication shall be performed as defined in FC-SP.

~~**Transition T3:T3.** If authentication does not complete within the timeout value defined in FC-SP, then the target FCP_Port shall remain in state T3.~~

Transition T3:T2. If FC-SP-2 requires the target FCP Port to perform fabric login, then the target FCP Port shall transition to state T2.

Transition T3:T4. If authentication as defined in FC-SP was successful, then the target FCP_Port shall transition to state T4.

~~**Transition T3:T10.** If authentication as defined in FC-SP was unsuccessful, then the target FCP_Port shall transition to state T10.~~

State T4: PLOGI. The target FCP_Port shall perform login with the Directory Service as defined in FC-GS-6.

Transition T4:T4. If an LS_ACC was not received in response to the PLOGI ELS Request, then the target FCP_Port shall follow the procedure defined in annex Annex A and shall ~~remain in~~transition to state T4.

Transition T4:T5. If a PLOGI LS_ACC from the Directory Service ~~has been~~s received, then the target FCP_Port shall transition to state T5.

State T5: Register. The target FCP_Port shall register with the Name Server by using the following CT_IU Requests:

- 1) Register FC-4 Type (RFT_ID) as defined in FC-GS-6. The FC-4 Types being registered shall include SCSI-FCP and Generic Fibre Channel Features;
- 2) Register FC-4 Feature (RFF_ID) for the SCSI-FCP FC-4 type as defined in FC-GS-6. The FC-4 Feature being registered shall include target (i.e., 01h) as defined in FCP-4; and
- 3) Register FC-4 Feature (RFF_ID) for the Generic Fibre Channel Features FC-4 type as defined in FC-GS-6. The FC-4 Feature being registered shall include Simplified Behavior declared.

The target FCP_Port ~~should~~shall register the Symbolic Node Name, if configured, and the Symbolic Port Name, if configured, with the Name Server by using the following CT_IU Requests:

- a) Register Symbolic Port Name (RSPN_ID) as defined in FC-GS-6; and

NOTE 14 - The type of information contained within the Symbolic Port Name is undefined. The intent is that the information be meaningful when displayed to an administrator.

- b) Register Symbolic Node Name (RSNN_NN) as defined in FC-GS-6.

NOTE 15 - The type of information contained within the Symbolic Node Name is undefined, but it should be identical across all interfaces connected to the same host platform. The intent is that the information be meaningful when displayed to an administrator.

Transition T5:T5. If the Name Server requests defined in state T5 completed by other than LS_ACC, then the target FCP_Port shall follow the procedure defined in annex Annex A and ~~remain in~~transition to state T5.

Transition T5:T6. If all of the Name Server requests defined in state T5 completed successfully, then the target FCP_Port shall transition to state T6.

State T6: SSE. The target FCP_Port shall transmit Server Session End (see FC-GS-6) to the Well Known Address of FFFFCh.

Transition T6:T7. If an Accept CT_IU was received in response to the Server Session End transmitted in this state, then the target FCP_Port shall transition to state T7.

Transition T6:T6. If the Server Session End request completed by other than LS_ACC, then the target FCP_Port shall follow the procedure defined in annex Annex A and shall ~~remain in~~transition to state T6.

State T7: SCR. The target FCP_Port shall instantiate the following state machines:

- a) PLOGI/PRLI state machine;
- b) RSCN state machine, if supported; and
- c) ~~Local event~~Target Internal Change state machine.

If a target FCP_Port supports reception of RSCN, then it shall register for state change notification by transmitting a State Change Registration (SCR) ELS Request to the Fabric Controller at address FFFFFDh as defined in FC-LS-2. The type of registration requested shall be "Full registration" (i.e., 03h).

Transition T7:T7. If the target FCP_Port transmitted an SCR and the SCR ELS Request was completed by other than LS_ACC, then the target FCP_Port shall follow the procedure defined in annex Annex A and shall ~~remain in~~transition to state T7.

Transition T7:T8. If the target FCP_Port:

- a) transmitted an SCR and an LS_ACC was received in response to the SCR ELS Request; or
- b) the target FCP_Port does not support reception of RSCN,

then the target FCP_Port shall transition to state T8.

State T8: Initial FC discovery. If the target FCP_Port supports discovery of initiator FCP_Ports~~discovery~~, then the target FCP_Port shall transmit a Get Port Names - Simplified Discovery for FCP (GPN_SDFCP) Request CT_IU as defined in FC-GS-6 with:

- a) The FCP Feature selection bit 1 (i.e., initiator) set to one;
- b) The Domain_ID scope field set to zero;
- c) The Area_ID scope field set to zero; and
- d) The Area_ID flag set to zero.

Transition T8:T8. If the target FCP_Port supports discovery of initiator FCP_Ports~~discovery~~ and the GPN_SDFCP Request was completed by other than an Accept CT_IU, then the target FCP_Port shall follow the procedure defined in annex Annex A and transition to state T8.

Transition T8:T9. the target FCP Port shall transition to state T9 if:

- a) an Accept CT_IU was received in response to the GPN_SDFCP transmitted in this state;
- b) the target FCP Port does not support discovery of initiator FCP Ports; or
- c) the target FCP Port does not require an Accept CT IU response to the GPN_SDFCP, then the target FCP_Port shall transition to state T9.

State T9: Normal operation. The target FCP_Port shall process and respond to SCSI_FCP commands as defined in FCP-4.

~~**State T10: Auth fail**— A target FCP_Port shall transition to this state for two reasons:-~~

- a) ~~the target FCP_Port has not set the security bit in the FLOGI/FDISC and the FLOGI/ FDISC LS_ACC has the security bit set; or~~
- b) ~~authentication as defined in FC-SP was unsuccessful.~~

~~**Transition T10:T1.** If:~~

- a) ~~the switch port has detected the Loss of Signal condition or Loss of Synchronization condition as defined in FC-FS-2, then the switch port shall transition to state T1; or~~
- b) ~~A change to the authentication configuration of the Switch has been made, then the switch port shall initiate the Link Initialization process as defined in FC-FS-2 and transition to state T1.~~

~~**Transition T10:T2.** If:~~

- a) ~~A change in the target FCP_Ports internal configuration results in support of the authentication protocol; or~~
- b) ~~A change in the N_Ports internal configuration has been made to the target FCP_Port that may result in authentication being successful;~~

~~then the target FCP_Port shall transition to state T2.~~

State T10~~4~~: Non-SCM switch - In this state, a switch that is not compliant with this technical report was detected. The target FCP_Port may perform discovery of initiator FCP_Ports by a means not defined by this technical report.

8.3.3 PLOGI/PRLI state machine

State T12: PLOGI/PRLI IDLE. ~~The target FCP_Port enters t~~This state is entered upon instantiation of the target FCP_Port PLOGI/PRLI state machine. While in this state, the target FCP_Port shall wait for PLOGI or PRLI requests to be received.

Transition T12:T13. If the target FCP_Port received a PLOGI or PRLI request, then the target FCP_Port shall transition to state T13.

State T13: Initiator processing. The target FCP_Port shall process requests from an initiator FCP_Port as follows:

- 1) Process Port Login requests and transmit an accept if resources are available;
- 2) Perform authentication, if required (see FC-SP); and
- 3) Process PRLI requests as follows:
 - A) If the Enhanced discovery bit in the PRLI request is set to one (see 6.2) and the target FCP_Port contains LUNs that are available for the initiator FCP_Port, the target FCP_Port shall transmit a PRLI accept;
 - B) If the Enhanced discovery bit in the PRLI request is set to one (see 6.2) and the target FCP_Port does not contain logical units that are available for the initiator FCP_Port, then the target FCP_Port shall reject the PRLI request with a reason code "Unable to perform command requested" (i.e., 09h) and reason code explanation "No resources assigned" (i.e., 52h) (see FC-GS-6); or
 - C) If the Enhanced discovery bit in the PRLI request is set to zero (see 6.2), then the target FCP_Port shall transmit a PRLI accept if it has resources available to do so.

Transition T13:T12. If all PLOGI and PRLI requests were processed, then the target FCP_Port shall transition to state T12.

8.3.4 RSCN state machine

State T14: RSCN IDLE. ~~The target FCP_Port enters t~~This state is entered upon instantiation the target FCP_Port RSCN state machine. While in this state, the target FCP_Port shall wait for RSCN requests to be received.

Transition T14:T15. If an RSCN ELS Request is received and the target FCP_Port has registered for state change notification, then the target FCP_Port shall transition to state T15.

Transition T14:T14. If an RSCN ELS Request is received and the target FCP_Port has not registered for state change notification, then the target FCP_Port shall transmit LS_RJT with an appropriate reason code and reason code explanation as defined in FC-LS and remain in ~~transition to~~ state T14.

State T15: RSCN. The target FCP_Port received an RSCN ELS Request. The target FCP_Port shall transmit an LS_ACC.

Transition T15:T16. If the target FCP_Port transmitted an LS_ACC in response to the RSCN ELS Request and the target FCP_Port supports RSCN FC discovery, then the target FCP_Port shall transition to state T16.

Transition T15:T14. If the target FCP_Port transmitted an LS_ACC in response to the RSCN ELS Request and the target FCP_Port does not support RSCN FC discovery, then the target FCP_Port shall transition to state T14.

State T16: RSCN FC discovery. The target FCP_Port shall perform only one of the following actions depending upon the format of the RSCN:

- a) If the format of the RSCN was Port Address format and contains only one N_Port_ID in the affected port ID List, then transmit one Get Port Name (GPN_ID) Request CT_IU as defined in FC-GS-6 to the Name Server specifying the 24 bit address of the affected port ID in the RSCN payload;
- b) If the format of the RSCN was Port Address format and contains more than one affected port ID's, then transmit Get Port Names (GPN_SDFCP) Request CT_IU as defined in FC-GS-6 with:
 - A) the FCP Feature selection bit 1 set to one; and
 - B) the Domain ID scope and Area ID scope bits set to include all ports in the affected port ID list; or
- c) If the format of the RSCN was Domain Format RSCN, then transmit Get Port Names (GPN_SDFCP) as defined in FC-GS-6 with:
 - A) the FCP Feature selection bit 1 set to one;
 - B) the Domain ID scope set equal to the value of the Domain in the RSCN; and
 - C) the Area ID scope bits set to zero.

If the payload of the accept CT_IU in response to the GPN_SDFCP:

- a) contains a Port Identifier and WWPN combination of an initiator FCP_Port that the target FCP_Port is currently logged in with, then the target FCP_Port shall:
 - A) process and respond to SCSI_FCP commands as defined in SPC-4 from that initiator FCP_Port; and
 - B) transmit an ~~Accept CT_IU~~ LS_ACC to any APDISC commands from that initiator FCP_Port.
- b) does not contain a Port Identifier and WWPN combination for a initiator FCP_Port that is currently logged in with the target FCP_Port, then the target FCP_Port shall:
 - A) ~~consider that initiator FCP_Port to be logged out~~ perform implicit logout with that initiator FCP Port; and
 - B) respond to any SCSI FCP command from that Port Identifier with a LOGO ELS until that initiator FCP_Port has performed login again.

Transition T16:T14. If RSCN FC Discovery completed, then the target FCP_Port shall transition to state T14

Transition T16:T16. If RSCN FC Discovery did not complete, then the target FCP_Port shall follow the procedure defined in annex Annex A and shall transition to state T162.

8.3.5 Target internal change state machine

State T17: Target State Change IDLE. ~~The target FCP_Port enters t~~ This state is entered upon instantiation of the target FCP Port Target internal change state machine. While in this state, the target FCP_Port shall wait for internal configuration changes to occur.

Transition T17:T18. If the internal configuration of a target FCP_Port changed and this change may change the number of LUNs available for any initiator FCP Port ~~response to a report LUNs command~~, then the target FCP_Port shall transition to state T18.

State T18: Target State Change. The target FCP_Port shall transmit an RSCN to the Fabric Controller with:

- a) the target FCP_Ports 24 bit address;
- b) the Event Qualifier of "CHANGED PORT ATTRIBUTE" (see FC-LS); and
- c) an Address Format of Port Address (i.e. 00h).

Transition T18:T17. #When the target FCP_Port transmitted RSCN to the Fabric Controller, then the target FCP_Port shall transition to state T17.

9 Requirements for an FCP_Port with initiator and target functions

9.1 Overview

In some instances N_Ports operate as both an initiator FCP_Port and a target FCP_Port (e.g., Remote replication of storage volumes, and data migration from one storage array to another). This technical report allows for these N_Ports by allowing the N_Ports to set both the FCP Feature selection bit 0 (target) and FCP Feature selection bit 1 (initiator) to one in the RFF_ID for the SCSI-FCP FC-4 type (see FC-GS-6).

9.2 Requirements

When the FCP_Port is operating as an initiator FCP_Port, it shall operate as defined in clause 6.

When the FCP_Port is operating as a target FCP_Port, it shall operate as defined in clause 8.

Annex A (Normative)

Retry Rules

A.1 Summary

At several points in the initiator FCP_Port, target FCP_Port and FC Switch state machines, a loop back transition is performed from one state back to itself. Most of these transitions occur in places in the state machine where forward progress in the state machine for the entire port is not possible until the current State completes. An example is the Transmit FLOGI state and the switch has not responded to the FLOGI. In this case, it is the intention of the loop back transition to allow the port to retry the state until successful.

In other places in the state machines, a loop back transition is used to indicate that some portion of a particular State was unable to complete. An example is PLOGI to a particular target FCP_Port and that target FCP_Port is non-responsive. In this case, it is the intention of the loop back transition to allow for retries to be performed.

A.2 Initiator FCP Ports or target FCP_Ports

A.2.1 LS_RJT or Reject CT_IU

If the response to an ELS or CT_IU Request is not LS_ACC, ~~and~~ the reason code is not retryable as defined in A.2.3, and the initiator FCP Port or target FCP_Port is a PN Port, then the initiator FCP Port or target FCP Port shall not retransmit the ELS or CT_IU Request until:

- a) In the case of a non-retryable reject of an FLOGI ELS, the device has performed Link Initialization; or
- b) In all other cases an RSCN is received.

If the response to the ELS or CT_IU Request is not LS_ACC and the reason code for the reject is retryable as defined in A.2.3, the initiator FCP Port or target FCP_Port shall wait E_D_TOV and retransmit the ELS or CT_IU Request.

A.2.2 Timeout

If an ELS Request does not complete within the timeout period defined in FC-LS-2, the initiator FCP Port or target FCP_Port mayshall retransmit the ELS ~~or CT_IU~~ Request

If a response to the CT_IU Request is not received within the timeout period defined in FC-GS-6, the initiator FCP Port or target FCP_Port mayshall retransmit the ~~ELS or~~ CT_IU Request

A.2.3 Reject reason code handling

A.2.3.1 Summary

Under certain circumstances, a device may find it necessary to reject a Link Service command with LS_RJT or reject a Name Server command with a Reject CT_IU. This clause defines which LS_RJT Reason Codes and Reject CT_IU Reason Codes are retryable. In the case of a retryable Reason code, the command can be retried after a period of time as specified in this technical report. All Reason Codes not defined here are non-retryable. For

non-retryable Reason Codes, the command shall not be performed again unless a configuration change has been made somewhere in the environment as defined in this technical report.

~~A Reason Code Explanations of xxh indicates that any Reason Code Explanation may be used.~~

A.2.3.2 LS_RJT retryable Reason Codes

~~The following are~~ Table 19 lists the retryable LS_RJT Reason Codes/Reason Code Explanations.:

Table 19 – Retryable LS RJT Reason Codes/Reason Code Explanations

<u>Code</u> ^a	<u>Name</u>
05h / xxh	Logical Busy
09h / 00h	Unable to perform command request / No Additional Explanation
09h / 19h	Unable to perform command request / Command (request) already in progress
09h / 29h	Unable to perform command request / Insufficient resources to support Login
<u>09h/48h</u>	<u>Unable to perform command requested / Authentication required (see FC-SP)</u>
^a <u>A Reason Code Explanations of xxh indicates that any Reason Code Explanation may be used.</u>	

A.2.3.3 Reject CT_IU retryable Reason Codes

~~The following are~~ Table 20 lists the retryable Reject CT_IU Reason Codes/Reason Code Explanations.:

Table 20 – Retryable Reject CT IU Reason Codes/Reason Code Explanations

<u>Code</u> ^a	<u>Name</u>
03h / xxh	Logical Error
05h / xxh	Logical Busy
0Dh / xxh	Server Not Available
0Eh / xxh	Session Could not be Established
^a <u>A Reason Code Explanations of xxh indicates that any Reason Code Explanation may be used.</u>	

A.2.3.4 Directory Service specific Reject CT_IU retryable Reason Codes

~~The following are~~ Table 21 lists the retryable Reject CT_IU Reason Codes/Reason Code Explanations for Directory Service CT_IU Requests.:

Table 21 – Directory Service retryable Reject CT_IU Reason Codes/Reason Code Explanations

Code	Name
09h / 00h	Unable to perform Command request / No Additional explanation