



# Distributed FCF

Claudio DeSanti

T11/11-070v1

Specification in T11/11-026v1

April 2011

# Agenda

- **FC-SW-6 Extensions**
- **FC-SW-6 Distributed Switch and Functional Models**
- **FC-BB-6 Functional Models and Distributed FCF**
- **VA\_Port Protocols**
- **Redundancy Protocol**

# FC-SW-6 Extensions

- Requested at the past meeting
- Done in 026v1

## FC-BB-6

### FDF Model Definition

- In order to answer these questions an FDF and its ports (VA\_Port) need to be rigorously defined just as other FC entities are defined
- Since the FDF is an end-point for some SW\_ILS's, this model needs to be defined in SW-6
- Once we have the model and agree upon the amount of FC functionality (control plane), we can have meaningful detailed discussions

2/8/2011

4



## FC-BB-6

### Switch Fabric SW-6

- Details need to be provided for
  - FDF Model (similar to the Basic Switch Model in SW-5 clauses 4 and 5)
  - VA\_Port
  - New ILSs
  - Modifications to existing SW\_ILSs to support the FDF, if any
  - Table depicting which SW\_ILSs are allowed or prohibited by the VA\_Port

2/8/2011

11



# Terminology

- **FC Terminology:**

- **Node**

- **Switch**

- **Distributed Switch:**

  - Controlling Switch(es)**

  - FCDFs:**

    - FC Data-Plane Forwarders

- **FCoE Terminology:**

- **ENode**

- **FCF**

- **Distributed FCF:**

  - Controlling FCF(s)**

  - FDFs:**

    - FCoE Data-Plane Forwarders

# 026v1

- **Defines the overall framework**
- **Divided in four chapters:**
  1. **Distributed FCF (i.e., the FC-BB-6 part)**

Defines the Controlling FCF and FDF functional models, the VA\_Port to VA\_Port Virtual Links, the FIP extensions and FIP ELP behavior
  2. **FDF/FCDF**

Defines the VA\_Port SW\_ILSs
  3. **Redundancy Protocol**

Defines the Controlling FCFs/Switches redundancy protocol  
Still very basic!
  4. **Distributed Switch (i.e., the FC-SW-6 part)**

Defines the Controlling Switch and FCDF functional models, the A\_Port to A\_Port Links, and the ELP behavior

# Agenda

- **FC-SW-6 Extensions**
- **FC-SW-6 Distributed Switch and Functional Models**
- **FC-BB-6 Functional Models and Distributed FCF**
- **VA\_Port Protocols**
- **Redundancy Protocol**

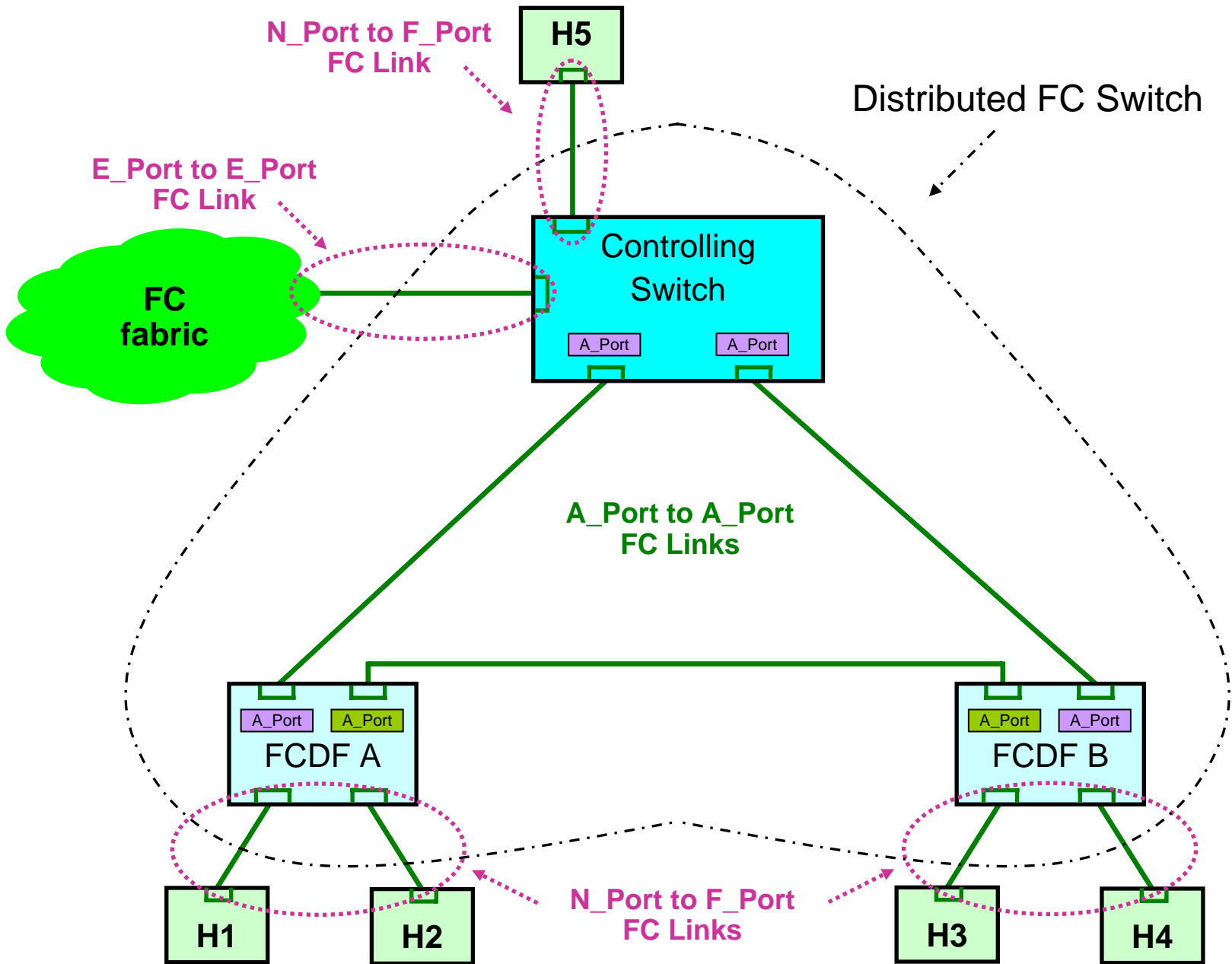

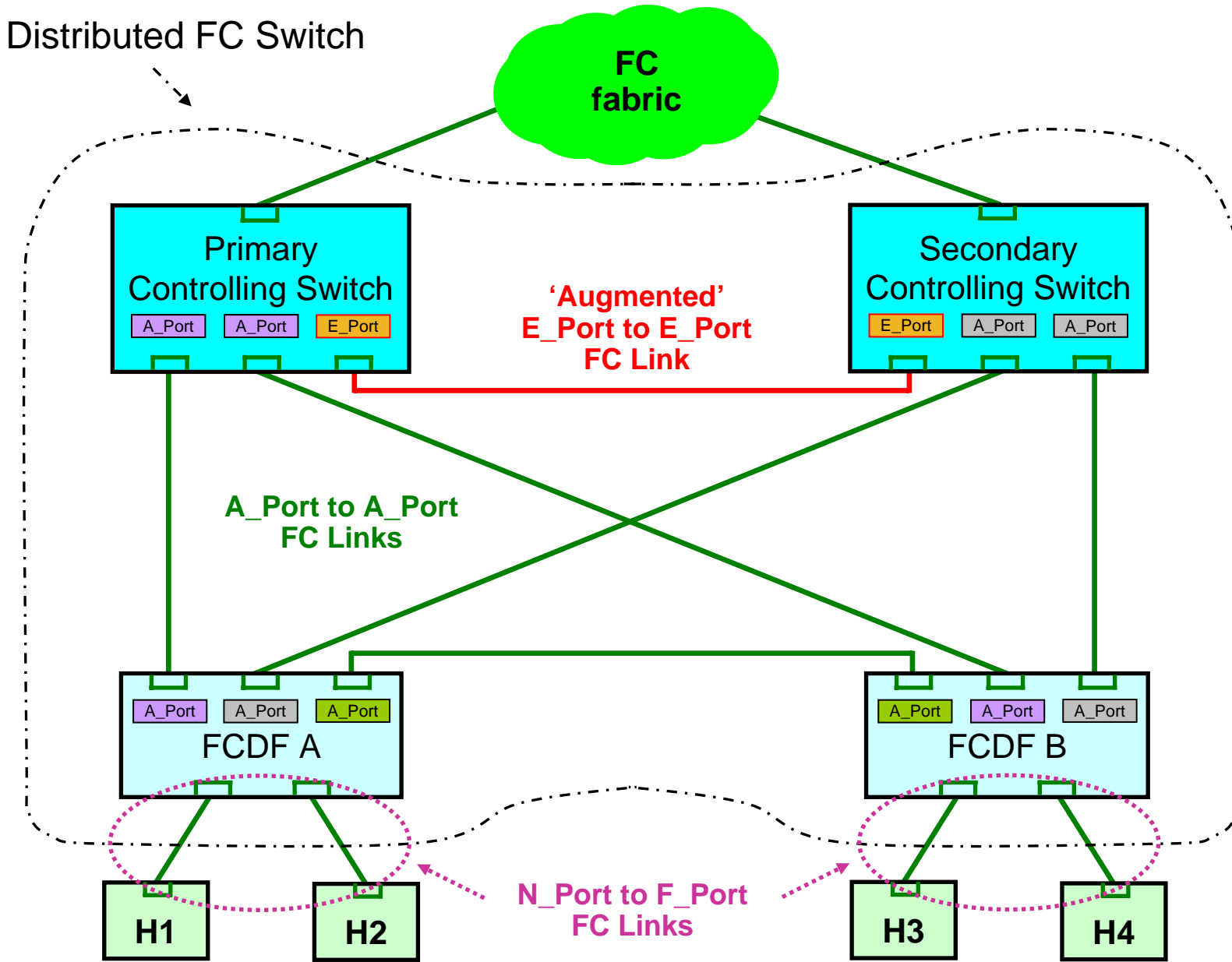

# Distributed FC Switch

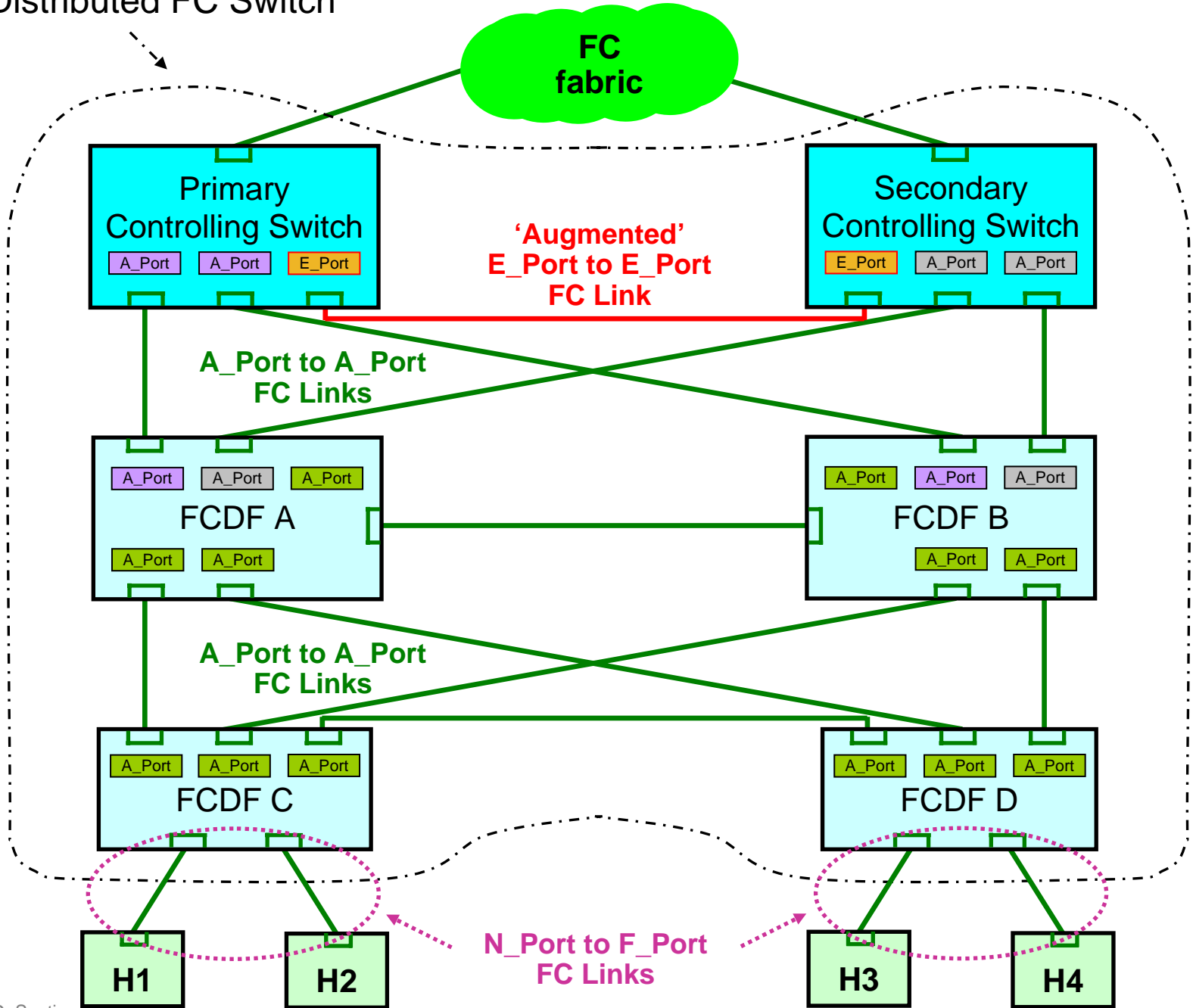

# Controlling Switch

- **The brain of a Distributed Switch**

  - Instructs the FCDFs on how they should forward FC frames

  - Receives information from the sensors (i.e., the FCDFs)

- **A Controlling Switch is an FC Switch supporting also:**

  - A\_Port protocols

  - Redundancy protocols over the 'augmented' E\_Port

# Controlling Switch Functional Model

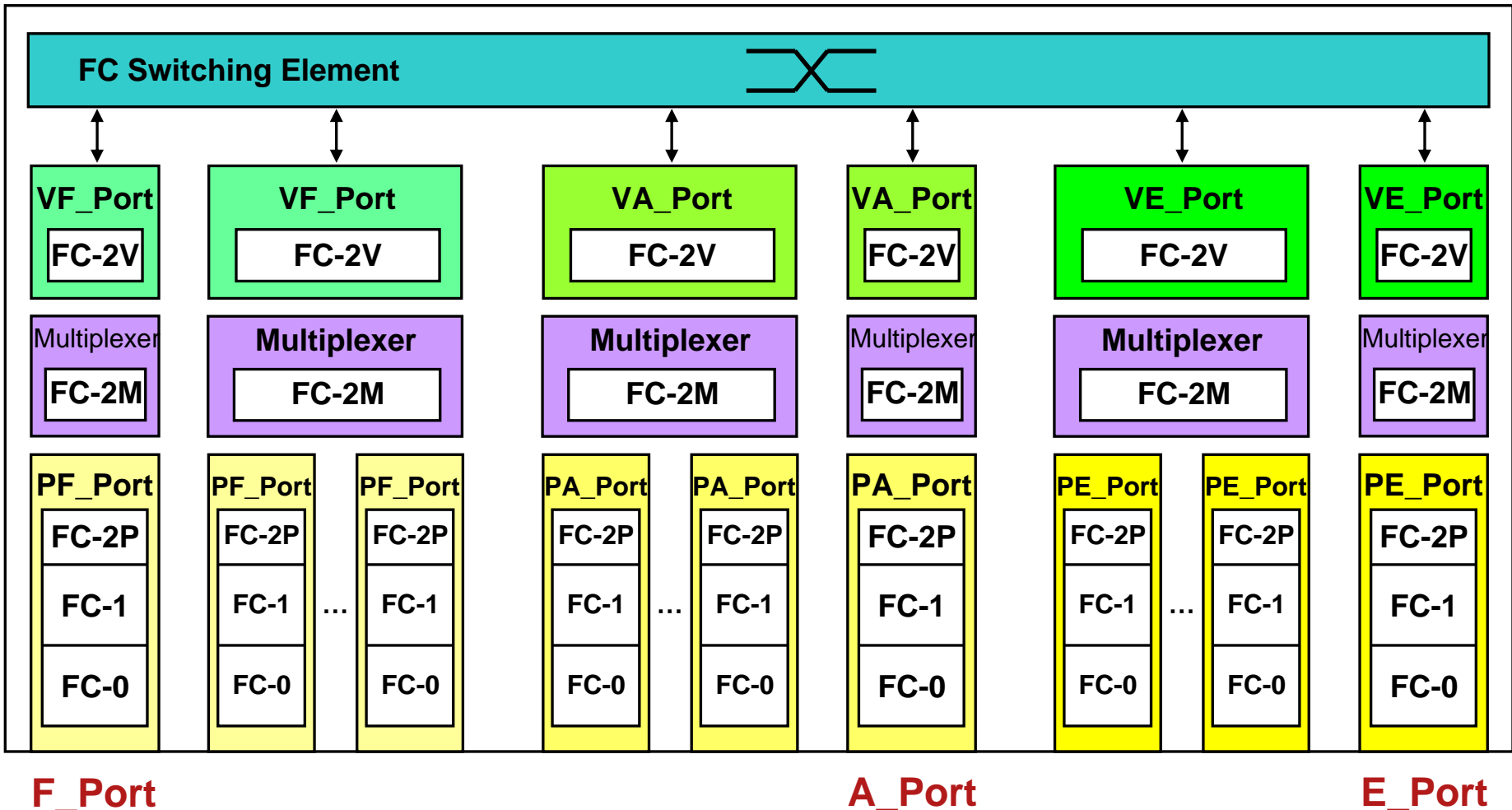

# FCDF: FC Data-Plane Forwarder

- **A Data Plane entity**

Forwards FC frames according to the Controlling Switch instructions

- **From a Control Plane perspective:**

**The Controlling Switch is the brain**

The central Control Plane entity

Instructs the FCDFs on how they have to behave

**The FCDFs are the sensors**

Tell the Controlling Switch about the links they establish

Receive instructions from the Controlling Switch

- **FCDFs can be cascaded**

# FCDF Functional Model

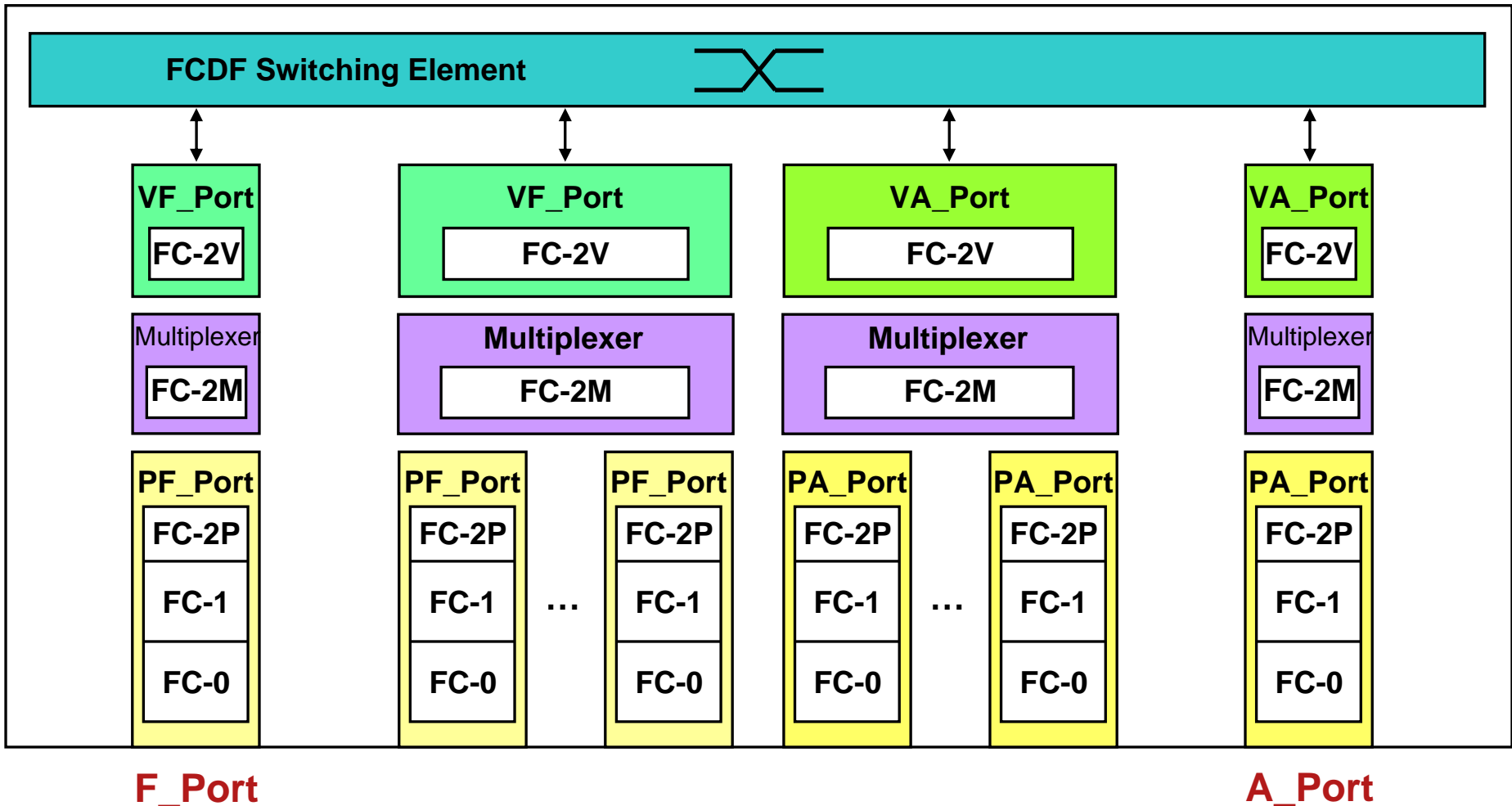

# FCDF Switching Element

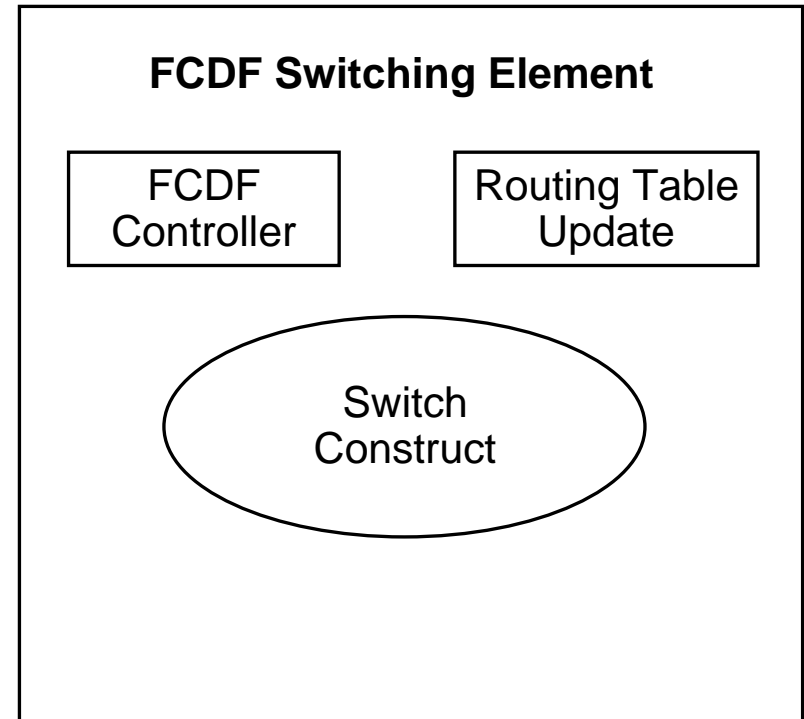
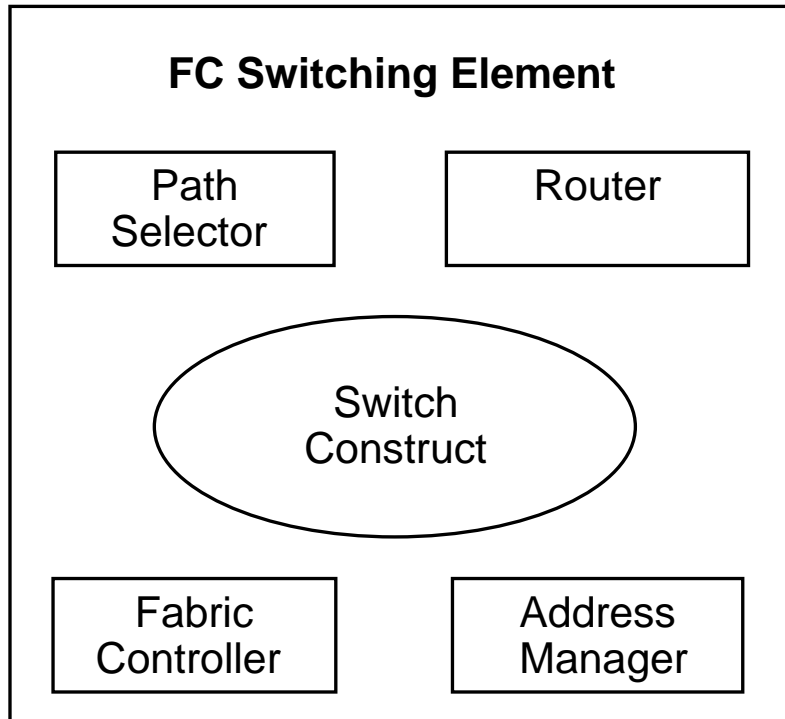

# A\_Port over FC-FS-3 Transport

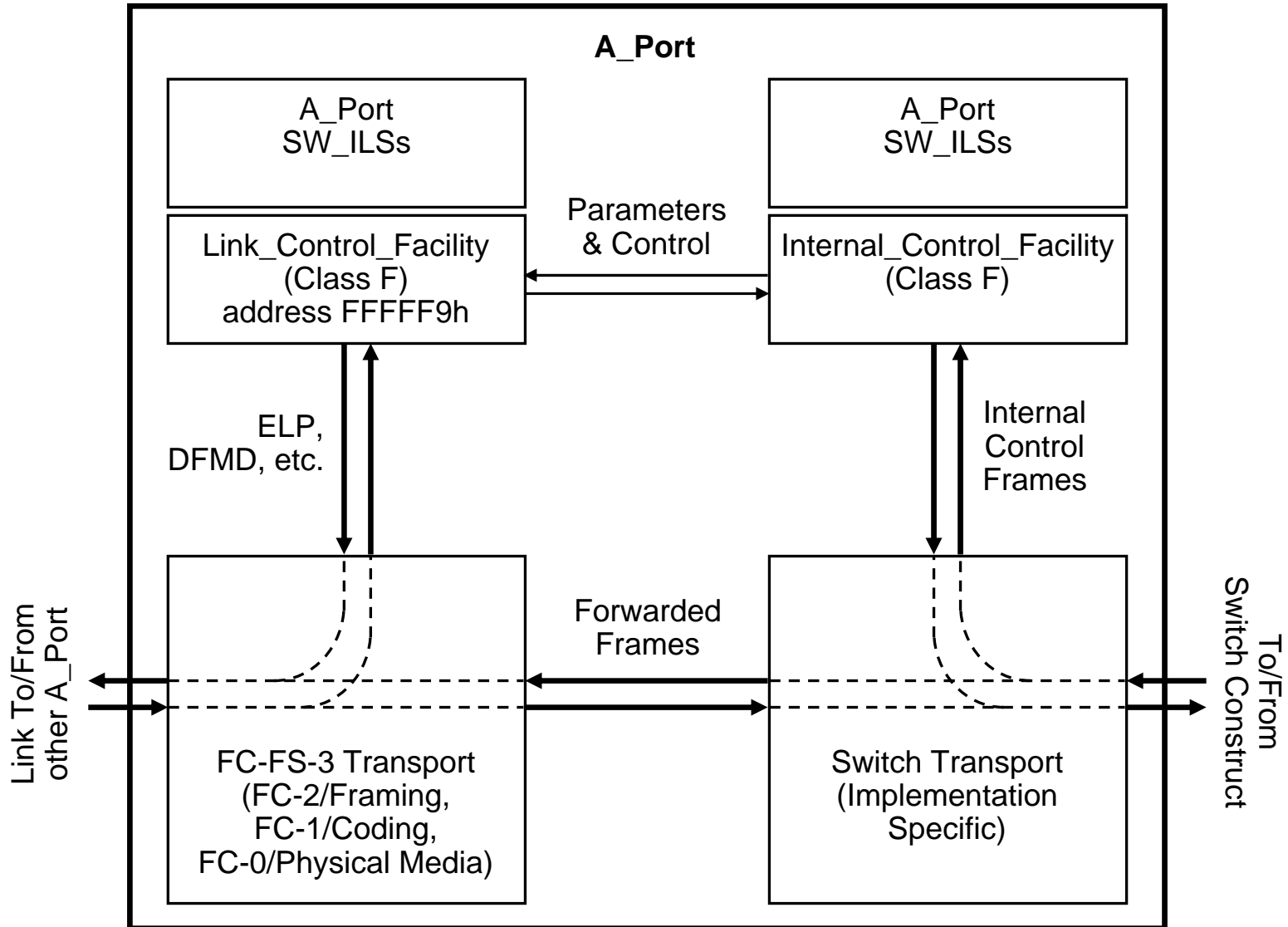

# Agenda

- **FC-SW-6 Extensions**
- **FC-SW-6 Distributed Switch and Functional Models**
- **FC-BB-6 Functional Models and Distributed FCF**
- **VA\_Port Protocols**
- **Redundancy Protocol**

# Controlling FCF Functional Model

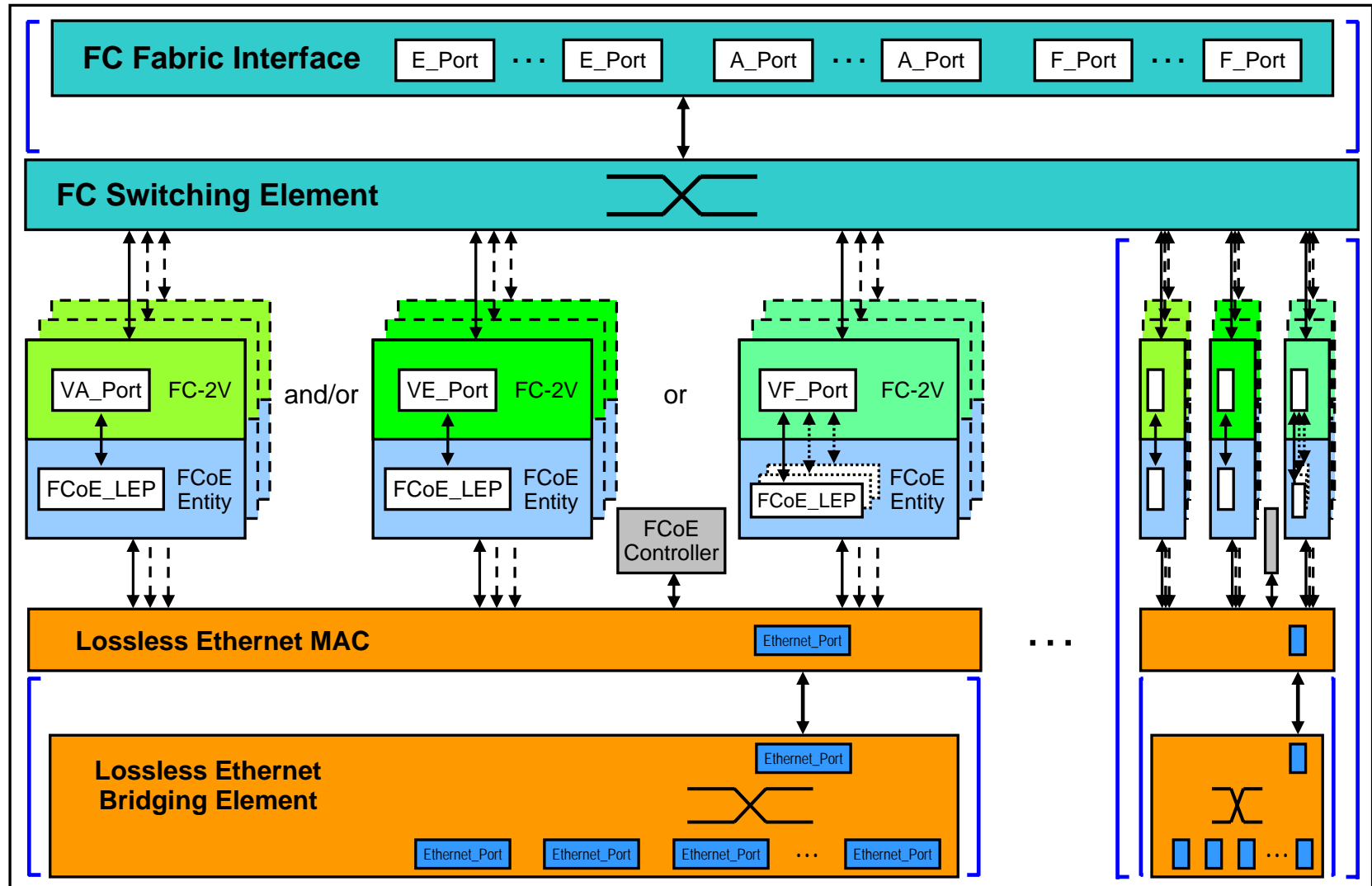

# FDF Model

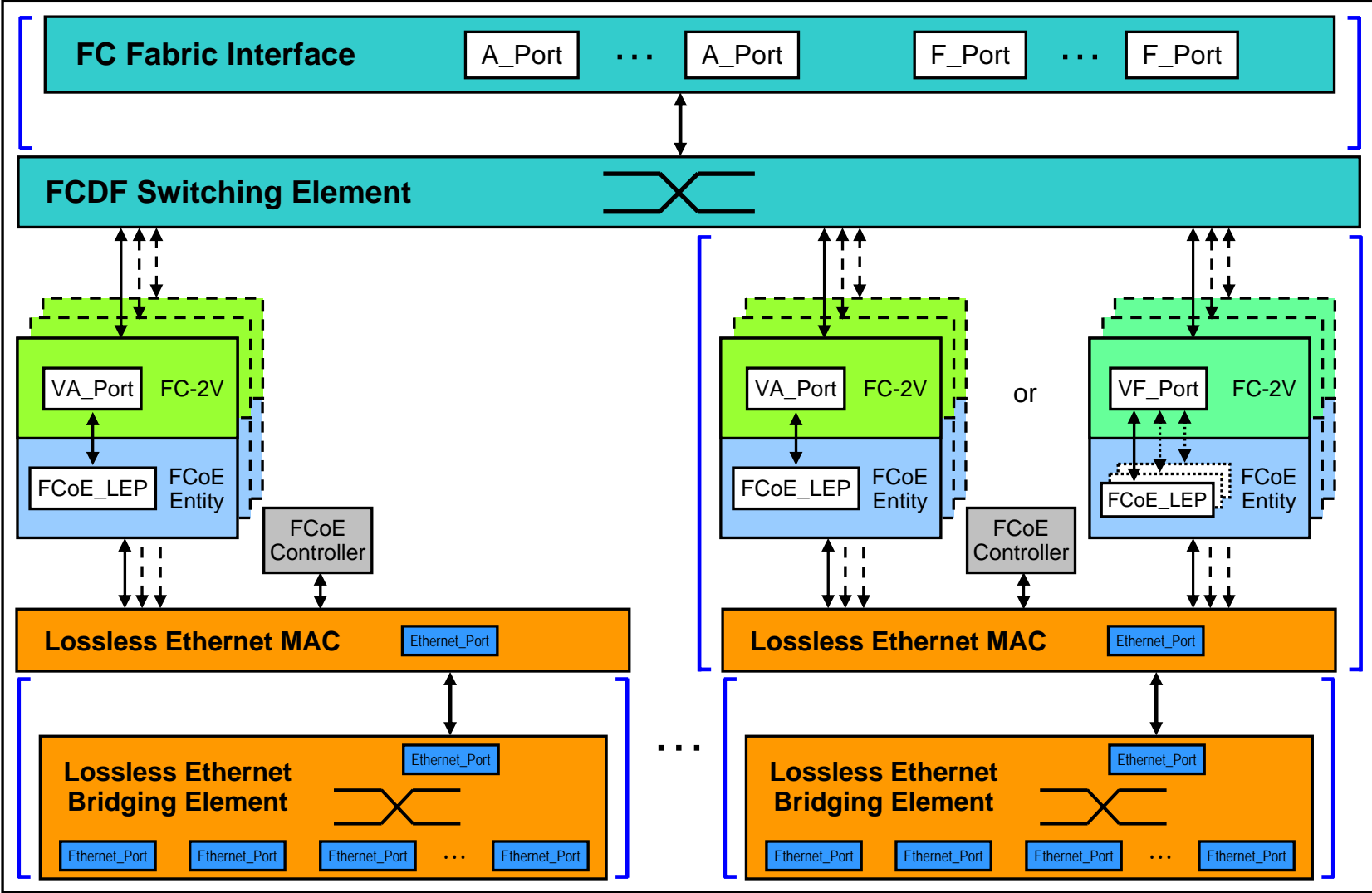

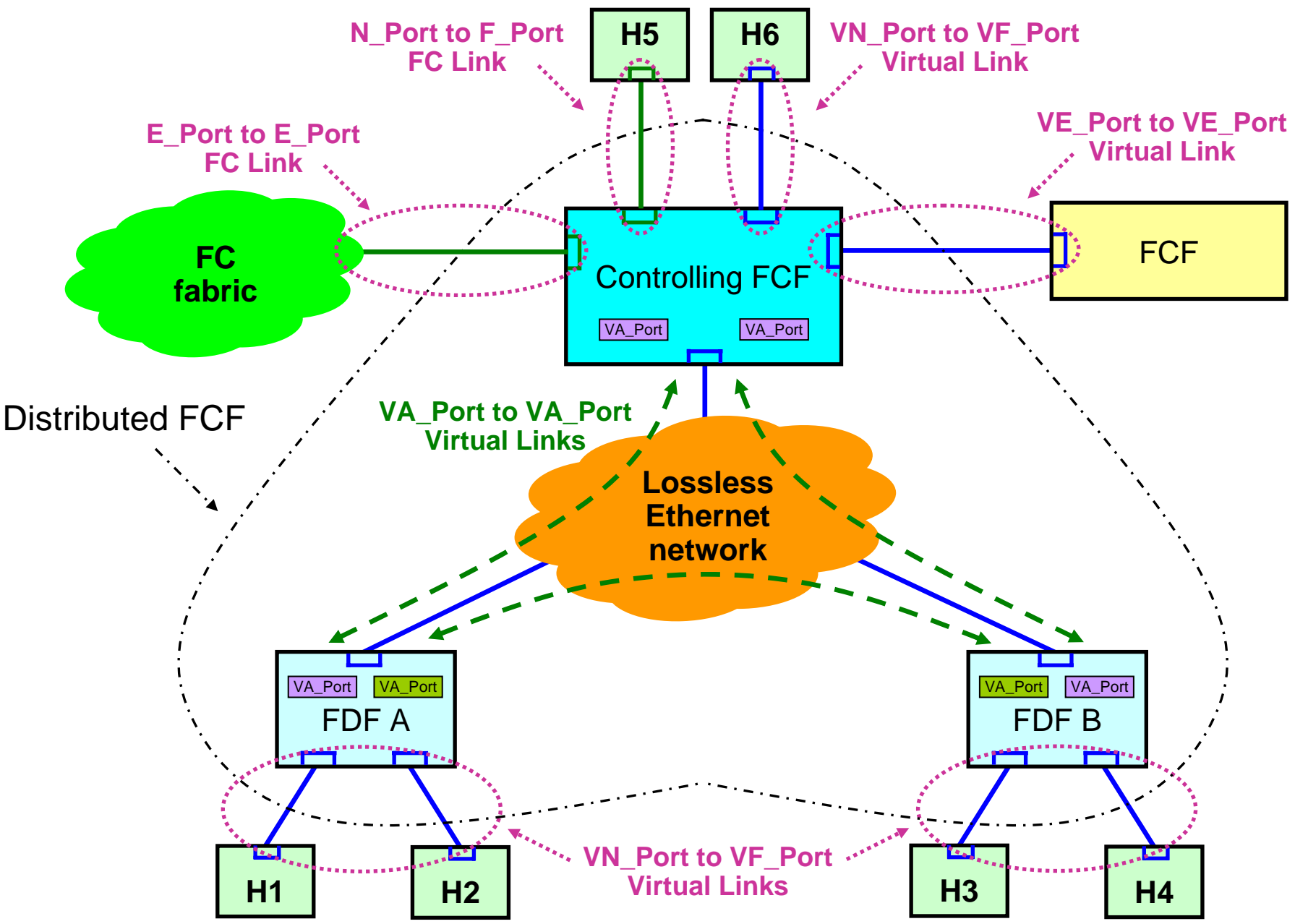

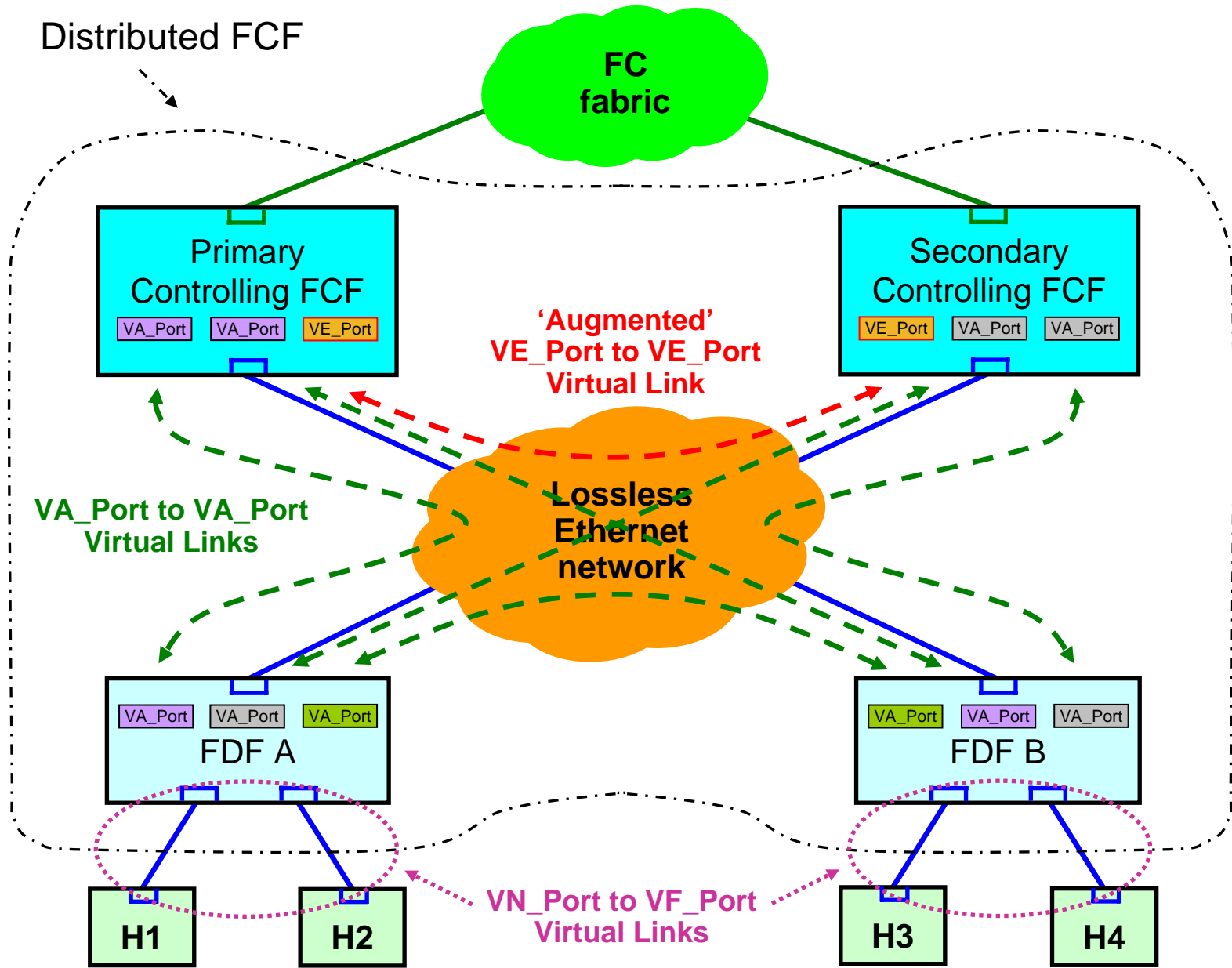

# Distributed FCF

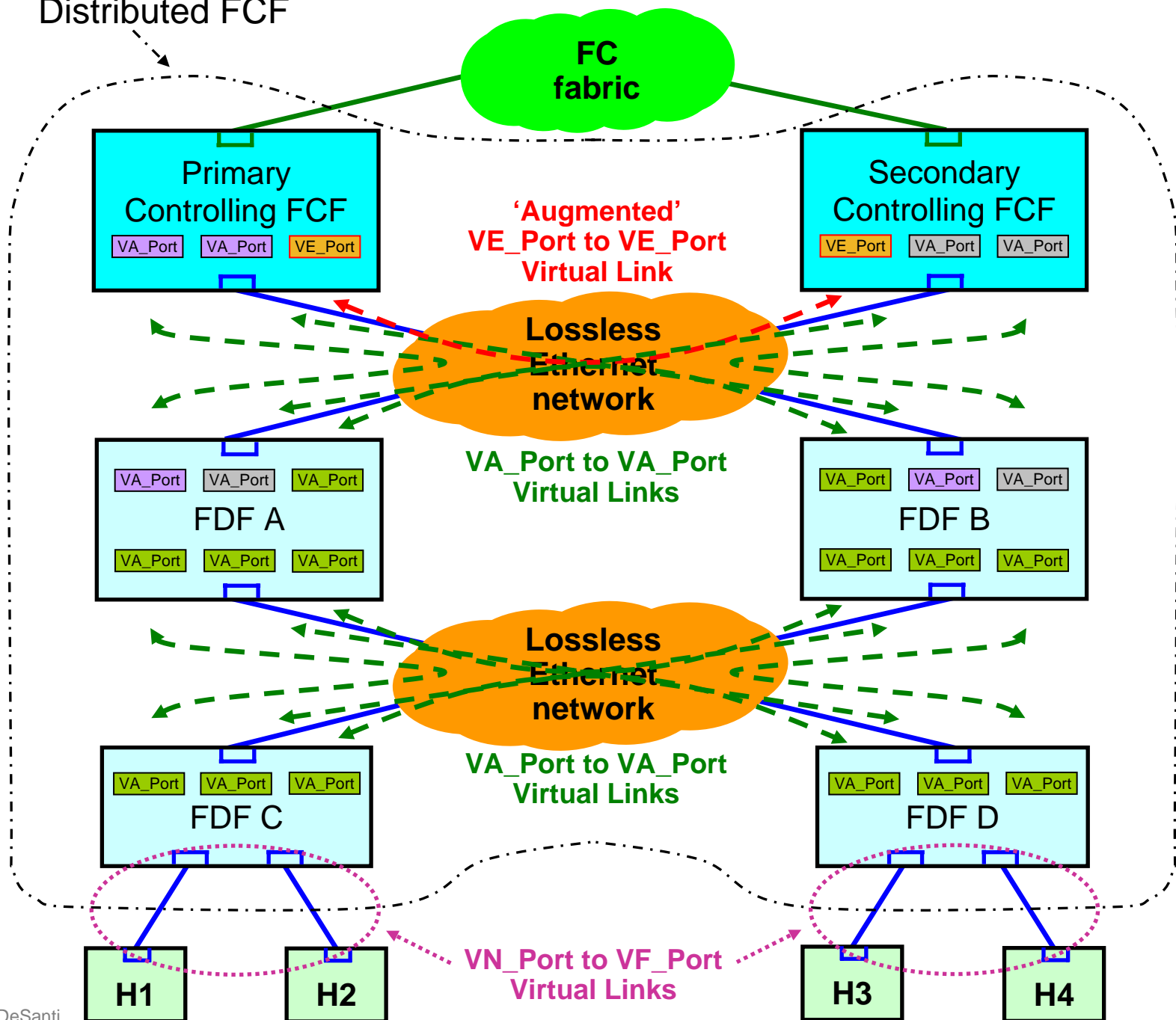

# Agenda

- **FC-SW-6 Extensions**
- **FC-SW-6 Distributed Switch and Functional Models**
- **FC-BB-6 Functional Models and Distributed FCF**
- **VA\_Port Protocols**
- **Redundancy Protocol**

# VA\_Port

- An instance of the FC-2V sublevel of Fibre Channel
- Identified by an A\_Port\_Name Name\_Identifier
- Addressed by the A\_Port Controller address identifier (i.e., FFFF9h)
- Supports Class F service, the VA\_Port SW\_ILSs, and their operations

Table 2 – VA\_Port SW\_ILSs Command Codes

Encoded Value	Description	Abbreviation
XX00 0001h	VN_Port Reachability Notification	VNRN
XX00 0002h	VN_Port Unreachability Notification	VNUN
XX00 0003h	FDF Reachability Notification	FDRN
XX00 0004h	FDF Unreachability Notification	FDUN
XX00 0005h	N_Port_ID Route Distribution	NPRD
XX00 0006h	N_Port_ID and Zoning ACL Distribution	NPZD
XX00 0007h	Active Zoning ACL Distribution	AZAD
XX00 0008h	Distributed FCF Membership Distribution	DFMD

# VA\_Port SW\_ILSs Relay

Originating FDF/FCDF or  
Controlling FCF/Switch

Intermediate  
FDF/FCDF

Destination FDF/FCDF or  
Controlling FCF/Switch

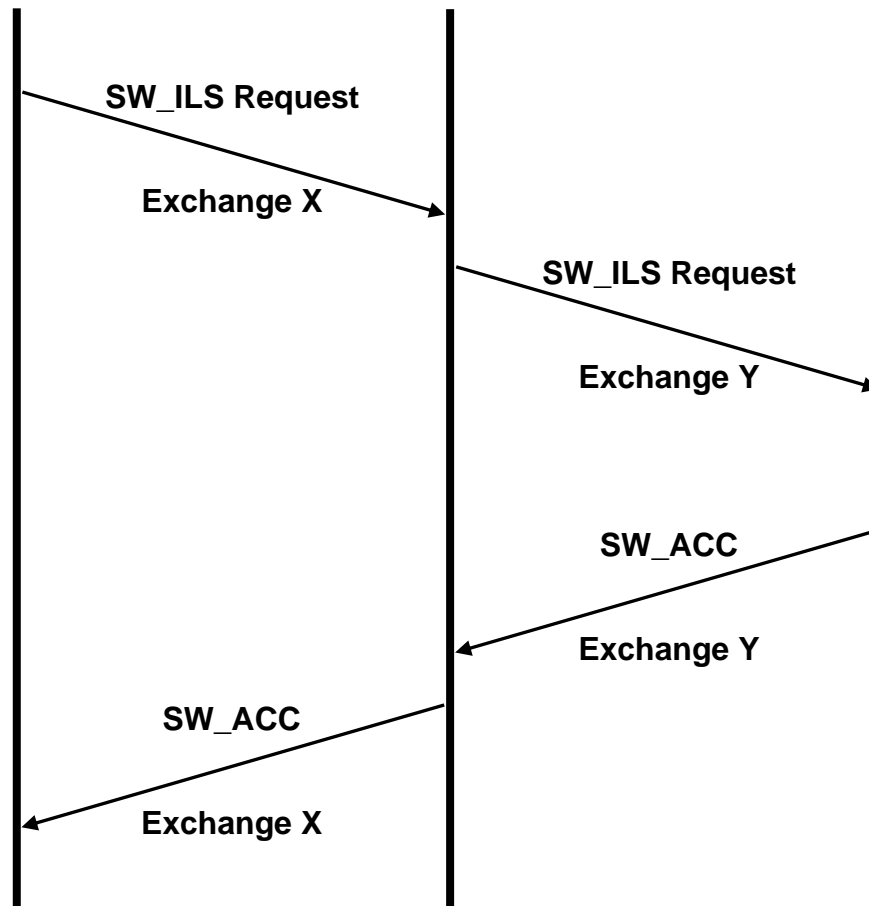

# Updated NPRD SW\_ILS (1)

Table 11 – NPRD Request Payload

Item	Size (bytes)
SW_ILS Code = XX00 0005h	4
Originating Controlling FCF/Switch Switch_Name	8
Destination FDF/FCDF Switch_Name	8
Primary Controlling FCF/Switch Switch_Name	8
Number of Equal Cost Paths to the Primary Controlling FCF/Switch (j)	4
Next-hop Switch_Name #1	8
Next-hop Switch_Name #2	8
...	
Next-hop Switch_Name #j	8
Secondary Controlling FCF Switch_Name	8
Number of Equal Cost Paths to the Secondary Controlling FCF/Switch (g)	4
Next-hop Switch_Name #1	8
Next-hop Switch_Name #2	8
...	
Next-hop Switch_Name #g	8
Number of N_Port_ID Range Entries (p)	4
N_Port_ID Range Entry #1	see table 12
N_Port_ID Range Entry #2	see table 12
...	
N_Port_ID Range Entry #p	see table 12
Number of Reachable Domain_ID Entries (r)	4
Reachable Domain_ID Entry #1	see table 13
Reachable Domain_ID Entry #2	see table 13
...	
Reachable Domain_ID Entry #r	see table 13

# Updated NPRD SW\_ILS (2)

Table 12 – N\_Port\_ID Range Entry Format

Item	Size (bytes)
Destination FDF/FCDF Switch_Name	8
Number of Equal Cost Paths to the Destination FDF/FCDF (w)	4
Next-hop Switch_Name #1	8
Next-hop Switch_Name #2	8
...	
Next-hop Switch_Name #w	8
Number of N_Port_ID Ranges (q)	4
N_Port_ID Range #1	4
N_Port_ID Range #2	4
...	
N_Port_ID Range #q	4

Table 13 – Reachable Domain\_ID Entry Format

Item	Size (bytes)
Destination Domain_ID	4
Number of Equal Cost Paths to the Destination Domain_ID (y)	4
Next-hop Switch_Name #1	8
Next-hop Switch_Name #2	8
...	
Next-hop Switch_Name #y	8

# Updated DFMD SW\_ILS

Table 20 – DFMD Request Payload

Item	Size (bytes)
SW_ILS Code = XX00 0008h	4
Originating Controlling FCF/Switch Switch_Name	8
Destination FDF/FCDF Switch_Name	8
Primary Controlling FCF/Switch Switch_Name	8
Secondary Controlling FCF/Switch Switch_Name	8
Number of FDFs/FCDFs (n)	4
FDF/FCDF Switch_Name #1	8
FDF/FCDF Switch_Name #2	8
...	
FDF/FCDF Switch_Name #n	8
Integrity Type	4
Integrity Check Value	32

# Agenda

- **FC-SW-6 Extensions**
- **FC-SW-6 Distributed Switch and Functional Models**
- **FC-BB-6 Functional Models and Distributed FCF**
- **VA\_Port Protocols**
- **Redundancy Protocol**

# Redundancy Protocol

- **Controlling FCF/Switch Check (CFC)**

The “heartbeat” signal

Table 23 – CFC Request Payload

Item	Size (bytes)
SW_ILS Code	4
Primary Controlling FCF/Switch Switch_Name	8
Secondary Controlling FCF/Switch Switch_Name	8

- **Virtual Domain\_ID Announcement (VDA)**

To negotiate the Virtual Domain\_ID value

- **Still unsatisfactory**

Improvements are needed

Thank you!

