

BROCADE



FC-BB-6

VN_Port to VN_Port Virtual Links

David Peterson, Brocade

Lou Ricci, IBM

Erik Smith, EMC

Roger Hathorn, IBM

T11/09-637v0

December 8, 2009

FC-BB-6 VN_Port <-> VN_Port Virtual Link

- Reuse current/existing functionality versus inventing new protocols
 - All FC services are utilized as is (SCN, zoning, authentication, etc..)
 - This benefits both switch (mainly) and ENode implementations
 - From an ENode perspective, all FC services like RSCN service, authentication, etc.. will continue to be available as they do today
 - Only change needed is (for ENodes) extra VN_Port discovery and “direct communication” mechanism



FC-BB-6 VN_Port <-> VN_Port Virtual Link

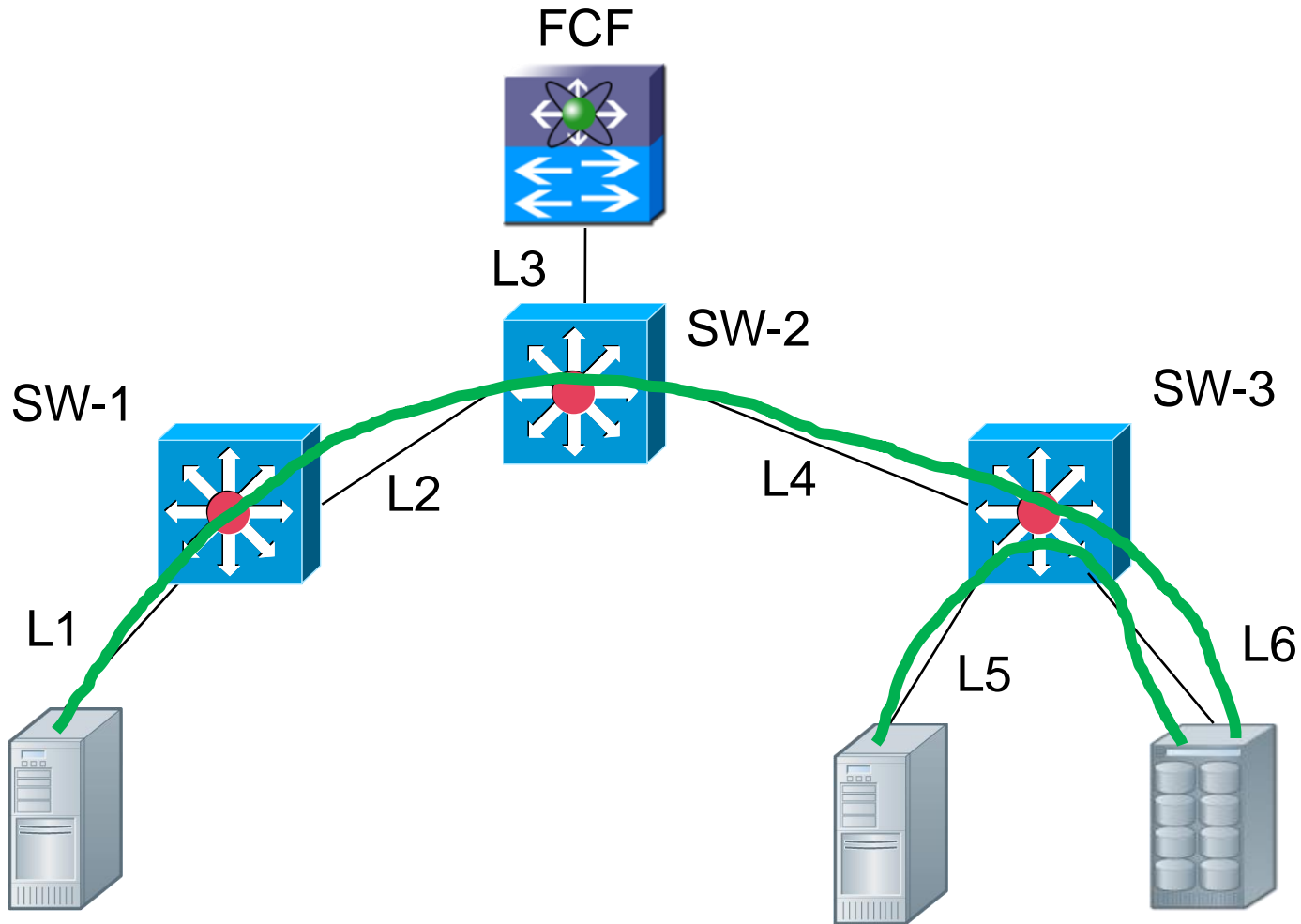

FC-BB-6 VN_Port to VN_Port Virtual Link

- VN_Port to VN_Port Virtual Link creation:
 - initiated by VN_Port/ENode
 - enabled by the FCF
 - path verification performed by the ENode/VN_Port
- All N_Port Login and N_Port Logout ELS's flow via FCF
 - Destination MAC address set to FCF MAC address
- All other traffic (e.g., FC-4 data, ELSs) flows through intermediate Ethernet bridges
 - Destination MAC address set to peer VN_Port MAC address



FC-BB-6 VN_Port to VN_Port Virtual Link

- ENode performs VLAN discovery, if needed (see FC-BB-5)
- ENode performs FIP discovery (see FC-BB-5)
- ENode performs FIP Fabric Login with FCF
 - Set the N (VN_Port) bit to one in FIP FLOGI descriptor (request) to indicate it supports VN_Port to VN_Port Virtual Links.
 - FCF responds with N bit set to one in FIP FLOGI descriptor (response) to indicate it supports VN_Port to VN_Port Virtual Links.
- VN_Port performs Login with Name Server via FCF



FC-BB-6 VN_Port to VN_Port Virtual Link

- VN_Port registers information with Name Server
 - VN_Port object (new) – (Note: FCoE attributes below may also be implicitly registered after FIP FLOGI)
 - VLAN ID
 - MAC address
 - Value of N bit in FIP FLOGI request descriptor (may not be needed as registering VN_Port object implies support for VN_Port to VN_Port Virtual Links)
 - FC-4 TYPEs object
 - FC-4 Features object
- VN_Port transmits (new) Gxx_xx query to the Name Server to obtain a list of VN_Ports that support VN_Port to VN_Port Virtual Links



FC-BB-6 VN_Port to VN_Port Virtual Link

- VN_Port transmits GID_FF query to the Name Server to obtain a list of the Port Identifiers of devices that support the desired protocol (e.g., FCP) and function (e.g., FCP target)
- VN_Port transmits PLOGI to remote VN_Port via FCF
 - i.e., destination MAC = FCF
- VN_Port transmits FIP Request VN_Port Virtual Link (RVL) to the FCF
- FCF transmits FIP Enable VN_Port Virtual Link (EVL) to the VN_Ports identified in the RVL
 - Intermediate Enet bridge sets up appropriate ACE(s) to allow VN_Port to VN_Port traffic (FIP and FCoE)



FC-BB-6 VN_Port to VN_Port Virtual Link

- VN_Port transmits FIP Verify Path to peer VN_Port upon receiving EVL
 - Destination MAC address set to peer VN_Port MAC address
- Upon receiving FIP Verify Path, VN_Port transmits FIP Path Verified to peer VN_Port
 - Destination MAC address set to peer VN_Port MAC address
- Upon receiving FIP Path Verified, VN_Port transmits FIP VN_Port Virtual Link Enabled to the FCF



FC-BB-6 VN_Port to VN_Port Virtual Link

- VN_Port to VN_Port communication is now enabled!
 - VN_Port transmits FC-4 specific frames (e.g., PRLI, SCSI INQUIRY, REPORT LUNS, via VN_Port to VN_Port Virtual Link)





VN_Port
(e.g., initiator)



SW-1



SW-2



FCF



SW-2



SW-3

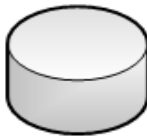

VN_Port
(e.g., target)

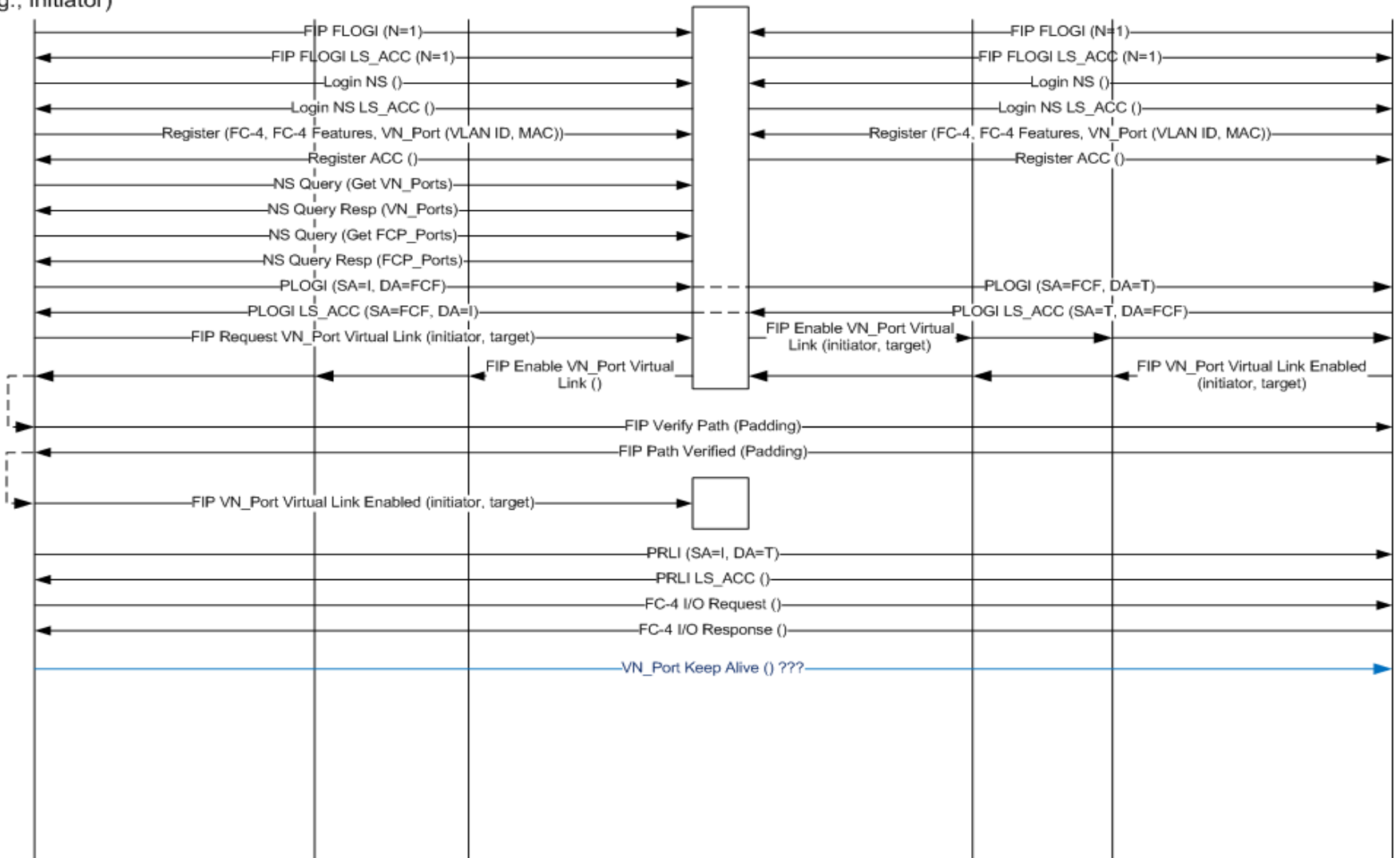

FC-BB-6 VN_Port to VN_Port Virtual Link Maintenance

- Working link keep alive, clean up, exception cases...stay tuned...



FC-BB-6 VN_Port to VN_Port Virtual Link Security

- Working VN_Port to VN_Port Virtual Link security requirements...



BROCADE



THANK YOU

