



# Fibre Channel over Ethernet: VFT\_Header and IEEE 802.1Q Tag

T11/07-416v0, July 2007

Claudio DeSanti, Cisco Systems

# VFT\_Header Purpose

- Allows to share a physical link across multiple Virtual Fabrics

Dividing a physical link in multiple logical links

- From FC-SW-4:

*The VFT\_Header allows Fibre Channel frames to be tagged with the Virtual Fabric Identifier (VF\_ID) of the Virtual Fabric (VF) to which they belong. Tagged frames (i.e., frames with a VFT\_Header) belonging to different Virtual Fabrics may be transmitted over the same physical link.*

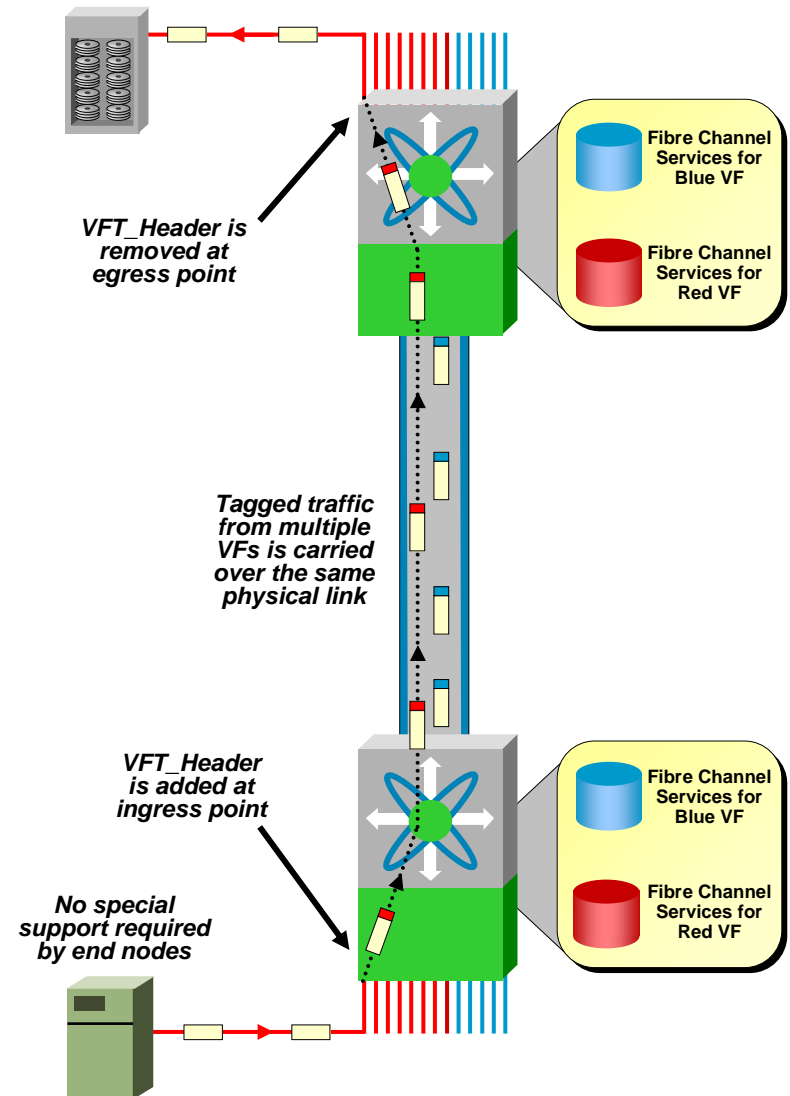

# VFT\_Header Usage (from FC-SW-4)

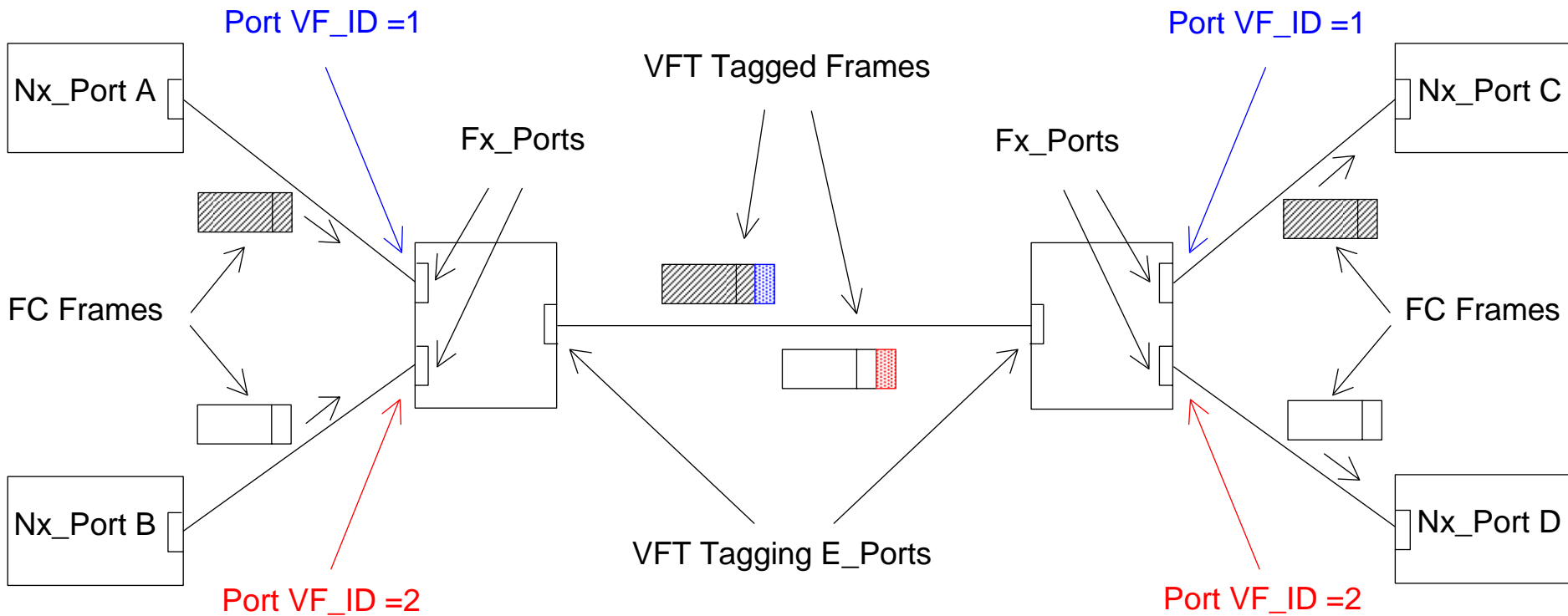

# VF Switch Model

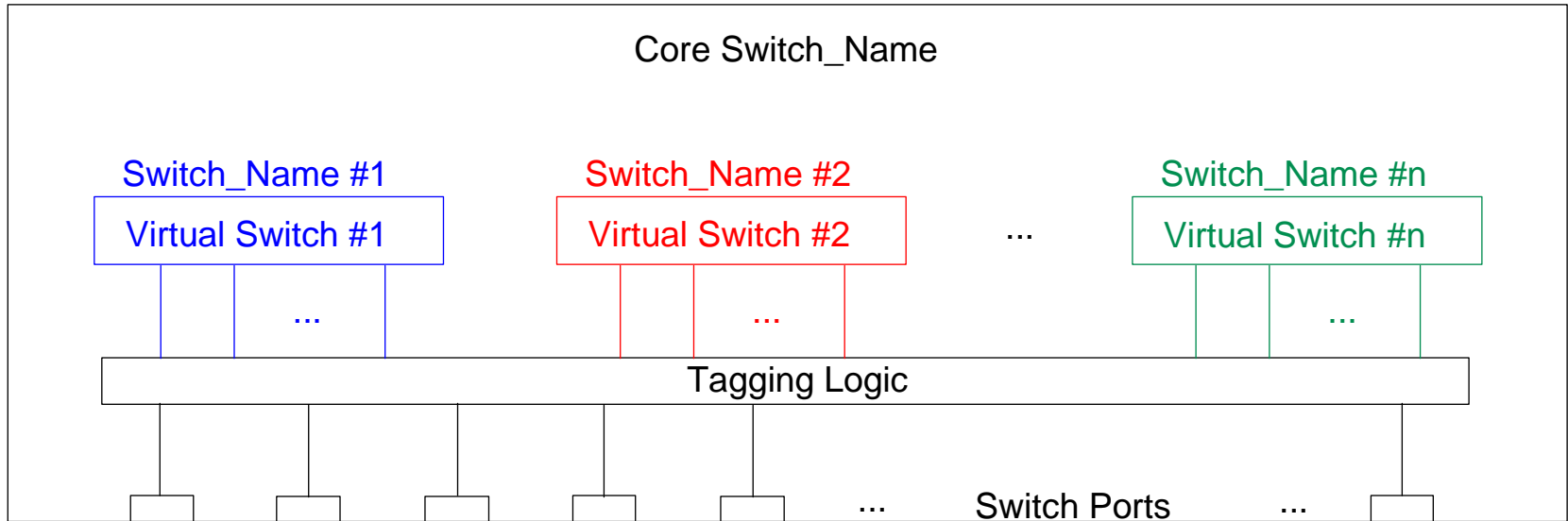

- **From FC-SW-4:**

*The tagging logic allows to share a physical link across multiple Virtual Fabrics using the VFT\_Header. The tagging logic is a multiplexer/demultiplexer driven by the VF\_ID in the VFT\_Header. Upon receiving a VFT tagged frame from a Switch Port, the tagging logic delivers the frame to the appropriate Virtual Switch (i.e., the Virtual Switch associated with the Virtual Fabric whose VF\_ID is carried in the VFT\_Header).*

# VFT\_Header: a Link Attribute

- VFT\_Header usage is optional
- VFT\_Header usage is negotiated on a per link basis
  - Only if the two link end-points support VFT\_Header tagging
  - The result of the negotiation protocol (defined in FC-SW-4) depends on the configuration of both end-points
- When tagging is enabled on a link, all frames on that link are tagged

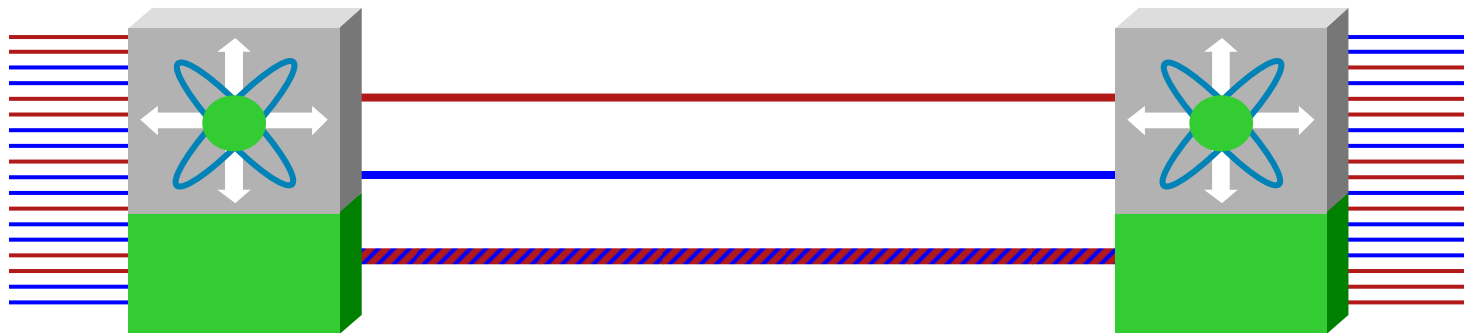

# VFT\_Header Use Example

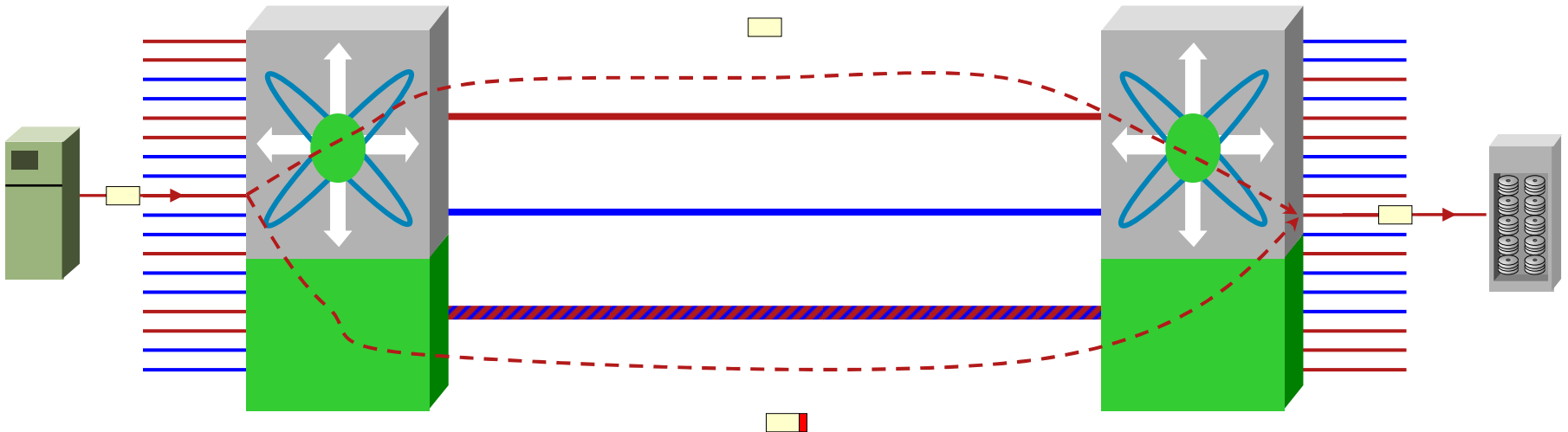

**Multipathing in the red VF**

**The VFT\_Header is a link attribute:  
It is added and removed hop-by-hop, as needed**

# IEEE 802.1Q Tag

- **Has the same purpose of the VFT\_Header**  
Sharing a physical link across multiple VLANs
- **Is optional to use**
- **Is a link attribute**  
Added and removed hop-by-hop, as needed
- **Model of an Ethernet switch supporting multiple VLANs:**

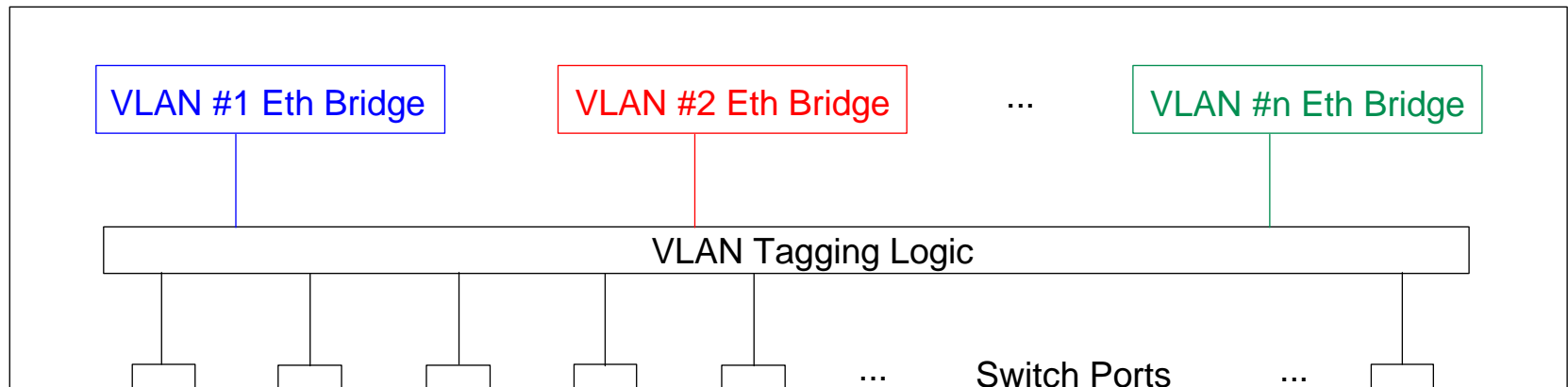

# The FCoE Case

- **The IEEE 802.1Q tag allows virtualization of a physical Ethernet link into multiple logical links**
- **The VFT\_Header allows virtualization of a physical FC link into multiple logical links**
- **In FCoE any link is logical**
  - A pair of MAC addresses
- **In FCoE the physical link is an Ethernet link**
  - The IEEE 802.1Q tag virtualizes it
- **Why two levels of virtualization tags?**

# Single Level of Virtualization Tag

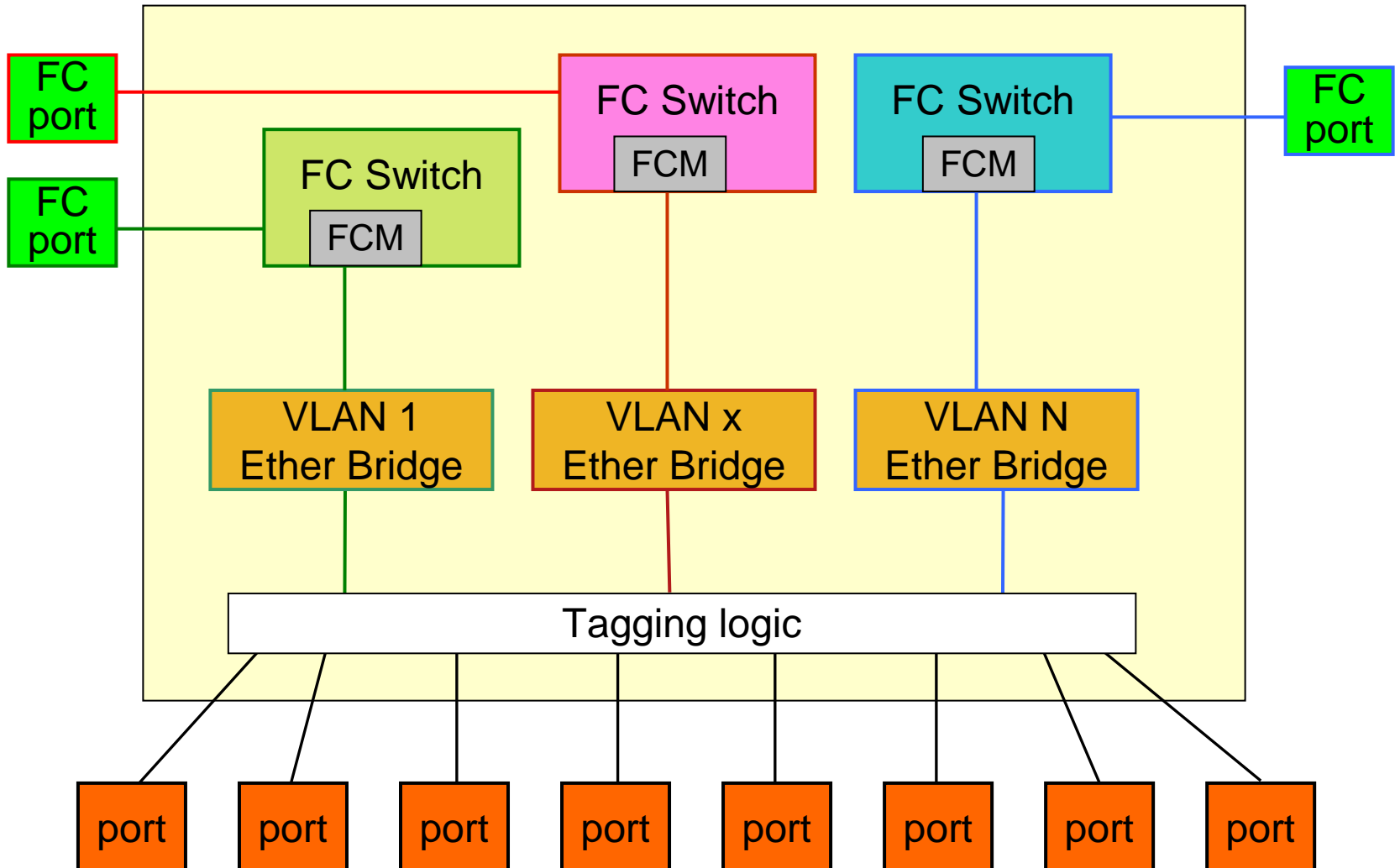

# Double Level of Virtualization Tags

